

C

O

L

A

2021

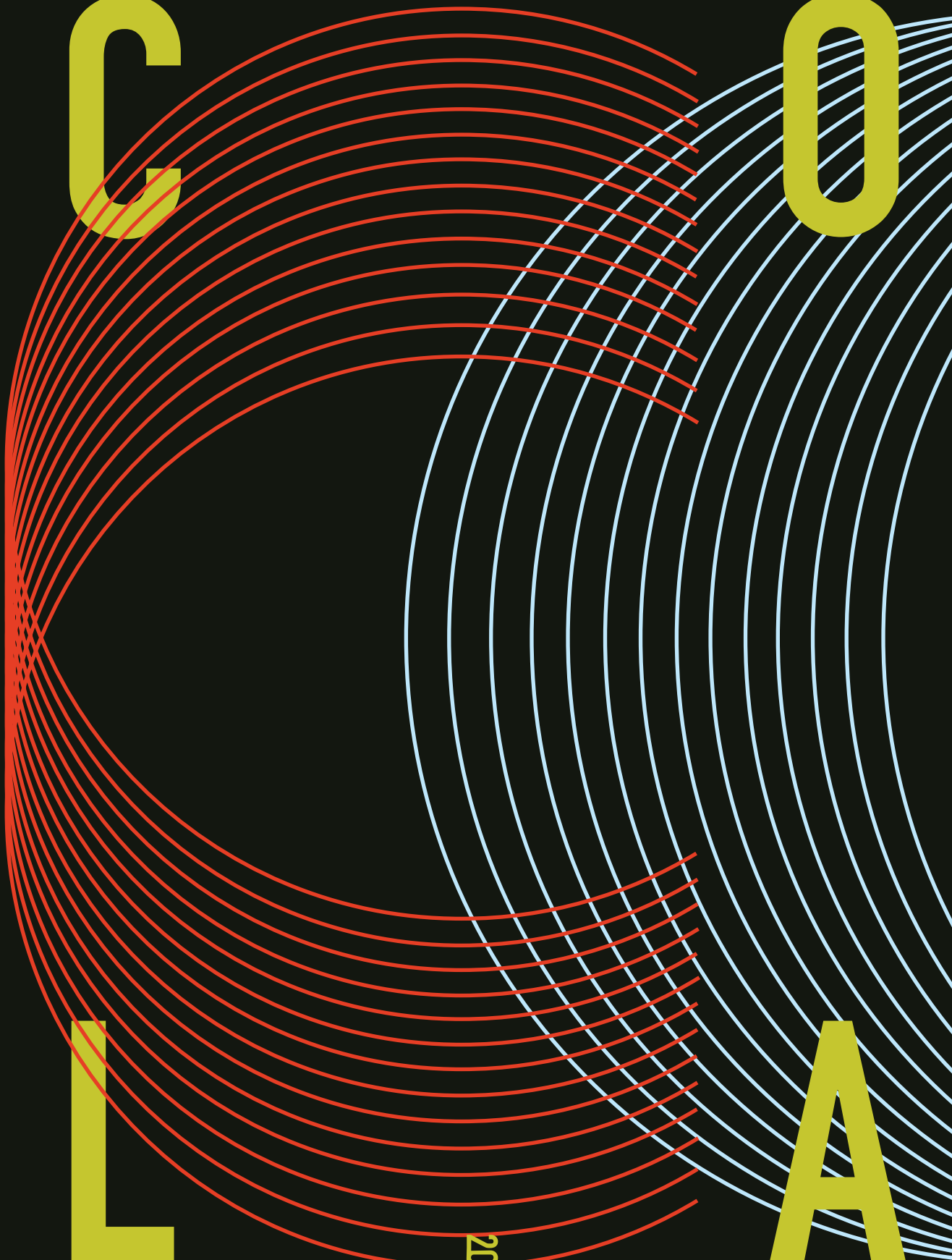

C O L A - 2021
Individual Artist
Fellowships

City of Los Angeles Department of Cultural Affairs

Eric Garcetti

Mayor
City of Los Angeles

Mike Feuer

Los Angeles City Attorney

Ron Galperin

Los Angeles City Controller

Los Angeles City Council

Nury Martinez
Los Angeles City Council President
Councilwoman, Sixth District

- Gilbert Cedillo, District 1
- Paul Krekorian, District 2
- Bob Blumenfield, District 3
- Nithya Raman, District 4
- Paul Koretz, District 5
- Monica Rodriguez, District 7
- Marqueece Harris-Dawson, District 8
- Curren D. Price, Jr., District 9
- Mark Ridley-Thomas, District 10
- Mike Bonin, District 11
- John S. Lee, District 12
- Mitch O'Farrell, District 13
- Kevin de León, District 14
- Joe Buscaino, District 15

Cultural Affairs Commission

- John Wirfs, President
- Elissa Scrafano, Vice President
- Evonne Gallardo
- Thien Ho
- Charmaine Jefferson
- Eric Paquette
- Robert Vinson

Department of Cultural Affairs
City of Los Angeles

As a leading, progressive arts and cultural agency, DCA empowers Los Angeles's vibrant communities by supporting and providing access to quality visual, literary, musical, performing, and educational arts programming; managing vital cultural centers; preserving historic sites; creating public art; and funding services provided by arts organizations and individual artists. Formed in 1925, DCA promotes arts and culture as a way to ignite a powerful dialogue, engage LA's residents and visitors, and ensure LA's varied cultures are recognized, acknowledged, and experienced. DCA's mission is to strengthen the quality of life in Los Angeles by stimulating and supporting arts and cultural activities, ensuring public access to the arts for residents and visitors alike. DCA advances the social and economic impact of arts and culture through grantmaking, public art, community arts, performing arts, and strategic marketing, development, design, and digital research. DCA creates and supports arts programming, maximizing relationships with other city agencies, artists, and arts and cultural nonprofit organizations to provide excellent service in neighborhoods throughout Los Angeles.

For more information, please visit culturela.org or follow us on Facebook at [facebook.com/culturela](https://www.facebook.com/culturela), Instagram [@culture_la](https://www.instagram.com/culture_la), and Twitter [@culture_la](https://twitter.com/culture_la).

Department of Cultural Affairs
City of Los Angeles

Danielle Brazell
General Manager

Daniel Tarica
Assistant General Manager

Will Caperton y Montoya
Director of Marketing, Development, and Design Strategy

Felicia Filer
Public Art Division Director

Alma Gibson
General Administrative and Support Program Director

Ben Johnson
Performing Arts Program Director

Joe Smoke
Grants Administration Division Director

Table of Contents

COLA 2021 Catalog

Editor: Will Caperton y Montoya
Designer: Garland Kirkpatrick
Copy Editor: Erik Benjamins
Photography and artists portraits: Josh Caffrey
Printing: Klaus Prokop, CANTZ, DE

Copyright 2021 by the City of Los Angeles
Department of Cultural Affairs

Original artwork courtesy of the individual artists
unless otherwise noted.

All rights reserved.

As a covered entity under Title I of the Americans with Disabilities Act, the City of Los Angeles does not discriminate on the basis of disability, and upon request will provide reasonable accommodations to ensure equal access to its programs, services, and activities.



**Department of Cultural Affairs
City of Los Angeles**
201 North Figueroa Street,
Suite 1400
Los Angeles, CA 90012

TEL 213.202.5500
FAX 213.202.5517

WEB culturela.org
TEL 213.202.5538
FAX 213.202.5511

FACEBOOK <http://www.facebook.com/culturela>
TWITTER [culturela.org](https://twitter.com/culturela)
INSTAGRAM [@culture_la](https://www.instagram.com/culture_la)

**Los Angeles
Municipal Art
Gallery**

**Los Angeles Municipal Art Gallery
Barnsdall Park**
4800 Hollywood Boulevard
Los Angeles, CA 90027
TEL 323.644.6269

Introductions

6-11

Danielle Brazell

General Manager
City of Los Angeles
Department of Cultural Affairs

Joe Smoke

Grants Administration
Division Director
City of Los Angeles
Department of Cultural Affairs

Isabelle Lutterodt

Barnsdall Park and
Los Angeles Municipal Arts Gallery
Director
City of Los Angeles
Department of Cultural Affairs

and

Jamie Costa

Los Angeles Municipal Arts Gallery
City of Los Angeles
Department of Cultural Affairs

Ben Johnson

Performing Arts Program Director
City of Los Angeles
Department of Cultural Affairs

COLA 2021 Individual Artist Fellowships

Visual / Design Artists
Literary / Performing Artists

12-97

COLA History

98

Acknowledgements

99

Introductions

In mid-March 2020 as the Department of Cultural Affairs (DCA) prepared to launch the City of Los Angeles (COLA) Individual Artist Fellowships program, Mayor Eric Garcetti issued the safer-at-home order to slow the spread of COVID-19. In support of this effort, DCA moved to rethink COLA, its flagship exhibition and performance series as virtual presentations. This was unknown territory at the time, yet we succeeded in developing online platforms and engaging audiences in a new way.

Over a year since those months of uncertainty, a year shaken by immeasurable upheaval and loss, the pandemic is still with us, but now we are no longer navigating uncharted waters. We are proud to bring you COLA 2021. The fourteen artists selected for this prestigious award represent the best in creative expression, and their unstoppably creative energy lights the path forward for our community.

During this pandemic we have seen people everywhere step-up to take care of our most vulnerable while demonstrating how to protect, serve, and heal from an incurable and merciless virus. Followed by a racial reckoning that remains unfinished. In the coming years, we will look back on recent history as divided into an era before COVID-19 and after. As I write, a few restrictions are being lifted, museums are re-opening with limited capacity, and performing artists' spaces are preparing to do the same. As we strive to return to normal, programs like COLA will be crucial to ensure the health of our creative ecosystem.

This catalog, produced by DCA, is a document to the resiliency, unwavering dedication, and invention of Los Angeles's community of artists. A group that has seen disproportionate effects of COVID-19 on its livelihood. The master artists featured here are representative of this spirit of persistence. They have been selected by a panel of peers, and invited to take their established work in any direction their inspiration leads them. The COLA Fellowship is an opportunity for artists to experiment, develop a new body of work, take chances, and be bold.

This catalog brings together new work by this year's ten design and visual artists, two literary artists, and two performing artists awarded the 2021 City of Los Angeles (COLA) Individual Artist Fellowships. COLA literary artists presented their work through video readings hosted by Grand Annex and produced by the Grand Vision Foundation; COLA performing artists presented works on videos with performances hosted by the Skirball Cultural Center and produced by Grand Performances. COLA design and visual artists were featured in a virtual exhibition organized by DCA's Los Angeles Municipal Art Gallery (LAMAG). I want to extend my sincerest thank you to the COLA partners, and to former COLA Design Fellow and catalog designer Garland Kirkpatrick, who together assisted DCA in presenting the work of these superb artists.

I congratulate the 2021 COLA Individual Artist Fellows on behalf of DCA and join the City in celebrating their achievements. COLA has continued since 1997 through many rocky moments in our history. Through it all, the artists give us a way to take stock in our experiences, which is especially important now in this time of dislocation, racial injustice, and uncertainty. As the great Modernist poet Marianne Moore wrote, art must be, "...lit with piercing glances into the life of things." An imperative you all meet.

Danielle Brazell

General Manager

City of Los Angeles Department of Cultural Affairs

"Vagabondage" is a term used by sociologists and others to describe the fulfillment we enjoy as we cycle between adventure and solitude. The COVID-19 pandemic has altered this healthy desire to mix extroversion and introversion. These many months have reduced our ability to wander beyond a few boxes such as homes and media-screens. Our physical and mental wellbeing has suffered without the complete freedom to travel and discover, attend community activities, congregate in public spaces, and mingle to meet new acquaintances.

But these uncomfortable months have also shown us how living systems are interconnected: substantial political, environmental, and healthcare events rise from a multitude of personal moments. This deeper perspective has reminded me of the concept of *immensity within ourselves*, described by Gaston Bachelard. He named this idea in *The Poetics of Space* (1958), as the mode for which our unconscious minds crave an *expansion-of-being* that only great threats (such as a global pandemic) might slow, but never halt, since our drive gets refueled during rest or meditation. According to this contemporary philosophy, as soon as we become motionless, we resume dreaming about some immensity, between grandeur and doom. And this balancing of inside/outside gets connected to our problem-seeking motivation, a wanderlust stirring within every motionless (or motion-limited) dreamer.

In the many opinions we are having now about how the world should change after COVID-19, we must reconcile how our economies are driven by the freedom to explore, and the desire to rebuild more equitable respect in human interactions. I desire to rebalance my own psychological dialectics, which have felt cheapened by telephone, television, and computer screens. Likewise, other artists and arts managers hope to reinvent how we can begin again at concerts, theaters, museums, and festivals. This communal-craving will ultimately regenerate unmasked smiles and larger acts of kindness for others, so deserving of appreciation and greater fortune.

The master artists in this catalog have worked in relative isolation to create expressions of enlightenment, following the trajectories of their careers during this historic episode. They represent a spectrum of praiseworthy avant-garde practitioners in Los Angeles, each producing socially valuable investigations, fabrications, and communications. The community experts who ranked and selected them for this honor believed that larger audiences deserved to enjoy their testimonies. Any shared themes, topics, or materials are coincidental, owing to the context of our regional mindset. They may or may not know each other and will not be assembled together in any gallery or theater to receive our applause, but we can agree from this catalog that they share an immense and powerful openness that motivates us beyond our current boxes.

Thank you in advance for experiencing this catalog as one small way to regenerate your own social-openness. Creativity should motivate an imperative to experience the world deeply, thoughtfully, and (soon again) directly. And within our shared polemic on *human immensity*, we can appreciate masterful local artists who are vigorously asking us and showing us how to know ourselves better through open questioning. How can an instance reflect our eternity? How will our eternity reflect this instance? Wherever we seek immensity, can we also feel intimacy? Where we seek intimacy, can we also experience immensity? Vagabondage lures us onward.

Joe Smoke

Grants Administration

Division Director

City of Los Angeles Department of Cultural Affairs

Introductions

On April 6, 2020 Mayor Eric Garcetti issued the Safer-At-Home directive essentially shutting down urban life in Los Angeles. The directive was issued in response to the global pandemic caused by the COVID-19 virus, forcing us to leave our workspaces and schools to pivot by making everything virtual. In the year we have spent home-bound we have learned much about ourselves and our individual and collective resilience as well as the importance of connectedness. This past year has seen domestic turmoil on a level many have never experienced in our lives. Civil unrest, a contentious and nerve wracking election cycle, and blatant acts of violence towards BIPOC people culminated in a siege of the Capitol building on January 6, 2021. There is anger, distrust, activism, and an awakening taking place.

In spite of these hardships, this year's City of Los Angeles (COLA) Visual Art Fellows generated work that touches on a range of topics which reflect this particular time. Many reflected on personal histories and stories that invite viewers to consider their relationships—with family, self, place, the world around and above us, past and present—to envision possibilities. Possibilities in visual language, material, and experience that prove art can be the greatest form to inspire, connect in dark or speculative times, and pave the way to a brighter future.

Edgar Arceneaux's series of abstracted paintings draws upon the artist's own emotional energy—refracted through a process involving the physical separation of the silver from the glass of mirrors—to play with the ideas, material aspects, and metaphors associated with mirrors.

Maura Brewer's latest essay film tells a parallel story—filmmaker Jess Bond's (formerly known as Jessica Manafort) pseudo feminist, neo-noir Rosy and Brewer's own investigative critique on its related aesthetics of money laundering and real estate fraud—to draw a portrait of the real politics, economics, and power hollowing out cities like Los Angeles.

In *Bloom*, Nao Bustamante has reimagined the speculum as a fantastical, organic, and pleasant instrument through a series of drawings that envision new, feminist aesthetic possibilities in a male-dominated medical field.

Exploring the idea of architectural follies and site specificity, Jedediah Caesar has digitally reimagined the Los Angeles Municipal Art Gallery with collaborators Vincent T. Arnado and Jessica Cua by rendering and embedding the strangely familiar forms of ammonites throughout the interior of the Gallery.

Neha Choksi's latest work, *Strata (bouquet)*, inherits the artist's interest in an interaction with the natural world and its relationship with time, the human bodies' laboring, and extraction through an installation of seven boulders, canvases, color pigment, and steel mirror.

With a consuming scale, material exploration and spirit of discovery, Lia Halloran's *The Sun Burns My Eyes Like Moons* includes layering and processes of cyanotype, photographic negatives and positives, and various mark making to expand notions of time and space experienced with solar events such as an eclipse.

In Farrah Karapetian's latest work, the artist re-embodies a group of women Surrealist, Pan African and Anti-Fascist thinkers from Paris and Martinique, who have been largely ignored by academia and creative communities until now, through a series of photograms and a collaborative script.

To unpack her childhood and family's experiences as refugees being in the United States, Phung Huynh plays with the idea of remembrance—from her subconscious memory, family narratives, community members, Vietnam War monuments, Hollywood film depictions, and educational institutions—and the asymmetrical disconnect in how traumatic experiences are contextualized and continue to be perpetuated today through a sculptural installation involving snow globes, photographs and G.I. Joe figurines.

Ruben Ochoa revisits his mobile art gallery, *CLASS: C*, with a series of bronze tortillas set in the original 1985 Chevy van his family used to sell tortillas as a

way to honor his family, the invisible labor of street food vendors and other businesses, and reflect on his creative practice as an artist of color in traditionally exclusionary exhibition spaces.

Featuring a reimagined, sculptural rendering of the Ishtar Gate and related paintings, *Per Capita* continues Umar Rashid's ongoing interest in the presentation of history and its weaponization, particularly against people of color, and the cultural signifiers that carry a mythologized trajectory of power and conquering as well as the acceptance of systems as individuals of populations.

Isabelle Lutterodt

Barnsdall Park and Los Angeles Municipal Arts Gallery

Director

City of Los Angeles Department of Cultural Affairs

and

Jamie Costa

Los Angeles Municipal Arts Gallery

City of Los Angeles Department of Cultural Affairs

Introductions

The City of Los Angeles, through the Department of Cultural Affairs, once again fulfills its mission of supporting four of the most forward-looking, LA-rooted artists actively and deeply creating work in our vibrant city. As we celebrate these four highly-regarded awardees of the City of Los Angeles (COLA) Individual Artist Fellowships, we make note of the generations of important and diverse performing and literary artists that have paved the way, and we recognize the Tongva, Chumash and Kizh Nations that have stewarded the land and water in which these artists live and create work.

This year's COLA Fellows continue to represent the kind of entrepreneurial spirit that has come to exemplify Los Angeles, as well as the way they speak to a multiverse of global experiences of our immigrant and Native communities, and our racial, community, and gender identities driving our activism that harness our artmaking. Performing and literary artists in LA have always been, and continue to be, at the forefront. This year's awardees represent the gloriously unique and inter/trans-disciplinary nature of our shared creativity as we value and uphold the experimental and innovative traditions that coexist within our multicultural ecosystem. Kudos to writer/performer Noel Alunit, fiction writer Michael Datcher, world percussionist Neel Agrawal, and choreographer Sarah Elgart.

Noel Alunit is a Filipino fiction writer and performer who explores gay themes, issues, histories and identities. Hailing from, and current resident of, Historic Filipinotown, he grew up as an artistically-motivated gay youth, and these experiences have informed his performance art and literary work. His artwork has been based on subjects such as the impact of the Marcos dictatorship on Filipinos in Los Angeles to broader ongoing effects of racism on the Filipino community. All of his history is centered through a queer lens with queer characters filling the landscapes of his stories. Early in his career, Mr. Alunit's theatrical leanings allowed him to create a highly regarded stage presentation including *The Rice Room: Scenes from a Bar* (1999-2001), and *Masters of the (miss) University* (2001). This early work led to a world of writing novels, short stories, and children's stories that continued to center on his Asian American and Pacific Island heritage with his LBGTQAQI2S+ identity. Writings include *Letter to Montgomery Clift* (2002) and *Talk of the Moon* (2007), and his latest novel, and the focus of his COLA project, a fictional account of a real person who was the Filipino valet for early gay filmmaker F.W. Murnau (*Nosferatu* – 1922) but who disappeared from written history after Murnau's death.

Fiction writer and inter-disciplinary artist Michael Datcher is an African American artist who uses his work to address and amplify socio-political issues within his community. Hailing from Berkeley, but now rooted in Venice Beach and Leimert Park, Dr. Datcher uses his passion, gifts, and activism to bring creative intersections to the multilayered and under-sung issues and histories affecting Black and Brown communities of Los Angeles and the broader American Experience. As a writer and thinker, he wants to use his writing to bring humanity to Black and Brown people who often were misconstrued as non-dimensional and mostly invisible. His life's goal is to give voice to those in his world with layers of complexity, nuance, uniqueness, beauty, and joy, and thus completely supplant the stereotypes and assumptions often misappropriately cast on the Black and Latinx community. His writing is prolific, and it exists in fiction, non-fiction, poetry, plays, articles, and presentations, and noted works include: *Raising Fences* (2001), *Americus* (2018), and *Animating Black and Brown Liberation* (2019). His COLA project is a novel-in-progress called *CULT* which tells the story of Flavia, a charismatic Religious Studies graduate student prodigy (who is writing a dissertation on People's Temple cult leader Jim Jones) and decides she wants to explore starting a "positive" women-centric cult because there have been so few women cult leaders—and because she wants to experience the power that male cult leaders have experienced.

Composer and performer Neel Agrawal is a South Asian multi-percussionist incorporating various styles of world percussion into his own unique musical

voice. Neel's contemporary solo style draws on his vast experience with performing and studying in a wide range of musical contexts including contemporary, fusion, Indian and Western classical, Brazilian, Afro-Cuban, rock, hip hop, electronic, theater, and film. He is known globally for his "rhythmic diplomacy" approach to solo percussion where he integrates themes of inclusivity into his unique performances, social justice, and education. His program, *Celebrate the Connections*, sponsored by the US Embassy in New Delhi, has traveled throughout India and in the United States. As a solo percussionist, Neel continuously fosters a critical and interactive experience among listeners by transcending genre and form. His constant investigation and experimentation of new forms of percussion has led him to collaborate with such cutting-edge groups as ZooLabs, Mipsterz, and Artwallah. Neel has an extensive background in research, specializing in topics such as South Asian history, foreign and international law, civil and human rights, and ethnomusicology. Through this background and with his commitment to marginalized communities, Mr. Agrawal will use his creative vision and COLA award to develop a new multimedia world percussion composition and immersive performance that will illuminate the South Asian-American experience in Los Angeles.

Award-winning choreographer and multimedia artist Sarah Elgart creates work that synthesizes visceral and highly physical dance and movement with visuals, film, and music to examine issues related to gravity, scale, time, distance, place, and the human condition. As an early pioneer in dance on film at the intersection of commercial, stage, and site-specific performance, she has used her platforms to explore the democratization of dance in performance and who can and cannot lay claim to it. In addition to circus and traditional proscenium houses, Sarah and her company, *Arrogant Elbow*, has created a wide variety of original works for public sites including airports, bus terminals, corporate plazas, gardens, and museums. Her work is about "painting" space with movement and singular imagery, and moving audiences so that each performance leaves a "ghost imprint" on their collective consciousness. Elgart's COLA award will be used to further expand her project, *Shape of Memory*. For this new work, she will create a site specific dance taking place within Skirball Cultural Center's landscaped rock garden. In terms of both form and movement, her piece is conceived as a somewhat autobiographical investigation of her relationship to dance and navigating the passage of time as a dancer/choreographer, as well as an investigation of the physical space in which the performance takes place.

Ben Johnson

Performing Arts Program Director

City of Los Angeles Department of Cultural Affairs

COLA-2021 Individual Artist Fellowships

Visual/Design Artists

Edgar **Arceneaux**

Maura **Brewer**

Nao **Bustamante**

Jedediah **Caesar**

Neha **Choksi**

Lia **Halloran**

Phung **Huynh**

Farrah **Karapetian**

Ruben **Ochoa**

Umar **Rashid**

Literary/Performing Artists

Neel **Agrawal**

Noel **Alumit**

Michael **Datcher**

Sarah **Elgart**

Panelists

Betty Avila

Leanna Bremond

Cassandra Coblenz

Sabrina Gschwandtner

Suzanne Lummis

Diana Nawi

Kamran V



Neel
Agrawal

If all you want from art is pleasure, no additional commentary on the work of Neel Kant Agrawal is necessary. Relax and enjoy. But for those in search of something more, those willing to listen closely and surrender expectation, Agrawal offers a much more complex and rewarding experience. Yet that

something more, which abounds in his soundscapes, cannot be grasped unless one maintains a fundamental openness to paradox.

The first paradox concerns labor. Agrawal is the rare virtuoso who harbors no elitist aversion to the grind, working gigs all over Los Angeles for the past eight years. Many of them, especially in the early going, were patently bizarre, unpaid, thankless, often unflattering. Coachella, showcases at UCLA, prestige performances in concert halls, awards like this one, all came much later. His latest projects involve scoring films and finding novel ways (especially in light of the pandemic) to use live performance as a means of community engagement and empowerment. As if that weren't enough, he balances this intense artistic workload against the rigors of an exhausting day job (he is also a dedicated librarian, archivist, and activist) and a demanding teaching schedule. With no time to spare Agrawal always makes time to play.

Onto the second paradox, which informs his training. Agrawal has an almost monastic devotion to classical form and technique because he knows that the surest path to music's experimental frontiers is through—and not in opposition to—tradition. So he immersed himself in an array of musical genres, seeking only that mastery which leads one to begin all over again, with jazz, Indian and European classical, rock, pop, and the American avant-garde. This study required both stylistic proficiency and a technical command over a wide array of percussion instruments, culminating in an eclecticism that seems effortless but is in truth profoundly earned. These days his practice routine is more consistent and intense than ever, bordering on religious ritual—daily artistic expression as ecstatic prayer, repetition as a primer for new breakthroughs.

The third and final paradox is personal. Agrawal is not a native Angeleno, but he nonetheless embodies the spirit of a diasporic and cosmopolitan L.A. His sound is shaped by his experience of the city—what he sees, feels, and hears everyday, but this impression of L.A. is mediated by the memory of those other places Agrawal once called home. In his music you will also hear the gardens of East Lansing, the marketplaces of Delhi, the coast of Santa Cruz, the libraries of Cambridge, and the forests of Seattle. His wager is simple: in some mysterious way our claim to the global, and perhaps even the cosmic, hinges on a radical commitment to the hyper-local.

With these paradoxes in mind, Agrawal and his latest composition, *Interscapes*, come into focus. The blending of organic percussive tambres with electronic melodies represents a rechannelling of ancient tropes through modern forms. The drumset, percussion instruments from South Asia (tabla), the Middle East (darbuka and frame drum), and Cuba (congas) are integrated so seamlessly that

**Born 1983,
Lansing, MI
Lives and works in
Los Angeles, CA**

Education	Mipsterz, Zoo Labs, Oakland, CA (group/solo)	2013 Lord Huron, Coachella, Indio, CA (group)
MLIS, University of Washington, Seattle, WA, 2012	2017 New Music Works, Santa Cruz, CA (group)	www.neelagrawal.com
JD, Michigan State University, East Lansing, MI, 2008	Golden Portal Project (w/ musicians from Herat, Afghanistan), Shared Studios & L.A. Law Library, Los Angeles, CA (group)	
BA, Michigan State University, East Lansing, MI, 2005	Selected Performances	
	2019 L. Shankar, Roulette, Brooklyn, NY (group)	2016 "Celebrate the Connections" Tour (U.S. State Department), New Delhi, India (group/solo)
	Khat-e Penhan / Hidden Line, Level Ground Festival, Los Angeles, CA (group)	2015 Borderlands, Subcontinental Drift Boston, East Meets Words, Cambridge, MA (group/solo)
	MetroArt, Union Station, Los Angeles, CA (group)	

they seem a part of him. The work is structured in accordance with this hybrid percussion setup and features world music luminary, L. Shankar on the double-violin and vocals. The music itself is set to an array of time signatures such as 4/4, 7/4, 6/4, and 12/8. Alongside contemporary styles, the piece utilizes traditional Indian rhythmic concepts such as *tala* (time cycle), *kaida* (theme and variation), *chakradhar* (a phrase repeated three times), *rela* (a fast compositional form), and *trikalam* (a phrase played at three different speeds).

And what, ultimately, does this composition mean? What is this paradox—uniting the granular and the infinite—at the core of Agrawal's work? Listen closely, let yourself go, and you will hear in his drumming, in every single beat, nothing more or less than the eternal spinning of the spheres through dark space, and the silent, almost imperceptible, beating of a heart.

Andrew Sivak, PhD

Still images from the new work titled *Interscapes* performed for video-broadcast on site at the Skirball Cultural Center, Los Angeles, CA. Photo: Josh Caffrey.



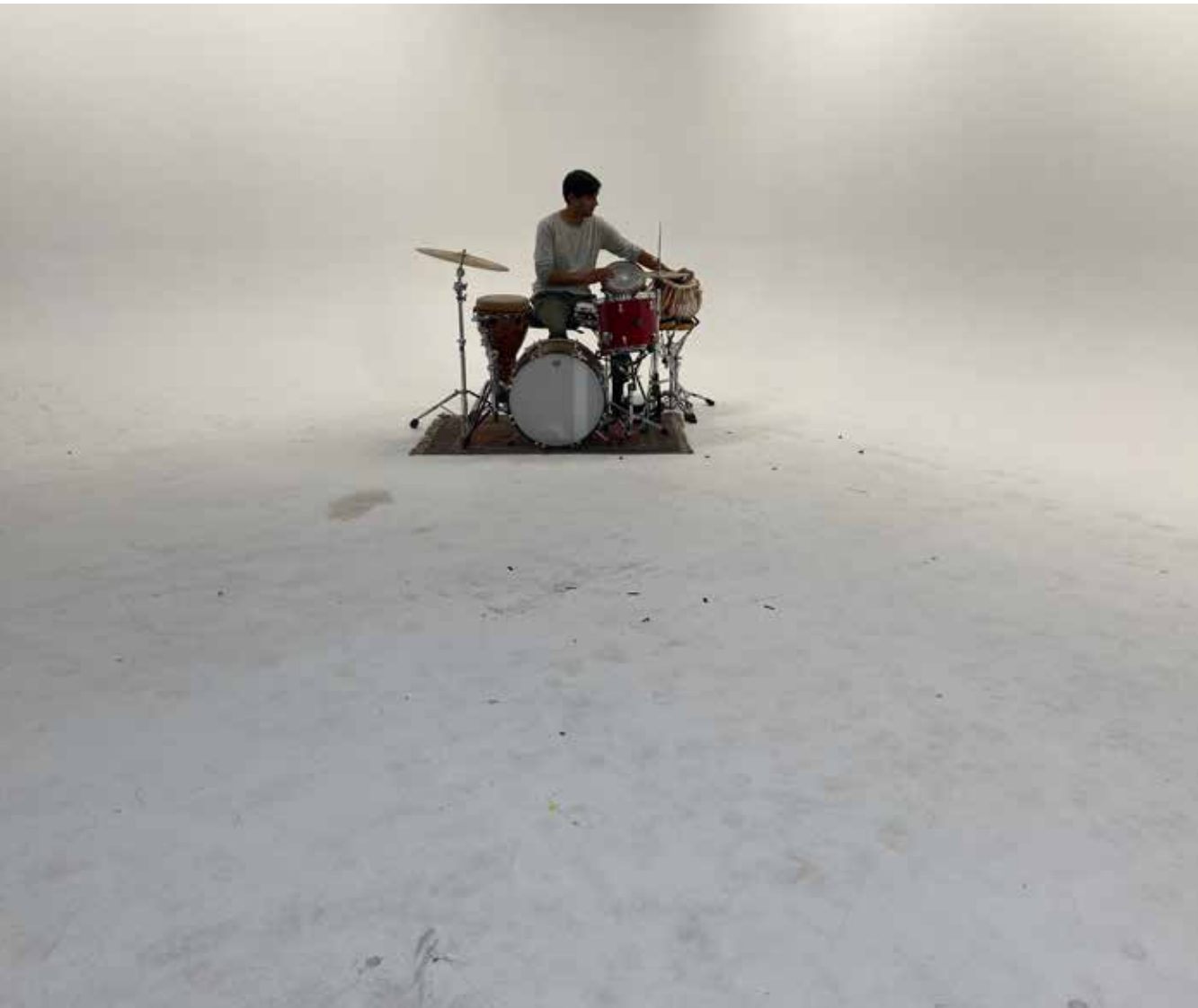

Khat-e Penham / Hidden Line, 2019.
Rehearsal at Level Ground Festival,
Los Angeles, CA. Photo: Gazelle Samizay.



Feature performance at Subcontinental
Drift Boston, Danger!Awesome,
Cambridge, MA, 2017. Photo:
SubDrift Boston.



Noel
Alunit

When you commit to sounding the clarion call for the voiceless, the less fortunate, the most vulnerable, the underrepresented, and the marginalized in your culture, it is most helpful to have as many trumpets to sound in as many places as possible. For nearly three decades, Noel Alunit has developed and mastered those trumpets

and amassed a staggering number of venues where he can call attention to his causes. He is an actor, a writer, an activist, and most recently, a Buddhist pastor who demonstrates an unwavering, lifelong devotion to the well-being and survival of the LGBTQ Asian community. Noel has accomplished the impossible, not by maintaining distance from the affairs or interests of other groups, but through collaboration, inclusion, participation, and consistency. Through teaching and learning, speaking his truth, and actively listening for the truth of others, he has the ability to make use of every ounce of a prodigious amount of energy.

In 1993, Alunit joined Asian Pacific AIDS Intervention Team (APAIT) and worked there until 2013, bringing attention to the devastating crisis in the Asian Pacific community. He wrote and performed his first play, *The Rice Room: Scenes From A Bar* (1999), and successfully brought much-needed attention to the conundrum of the invisible-yet-fetishized young, gay, Asian man. The *San Francisco Chronicle* proclaimed it one of the best solo productions of the year. This was followed by another solo effort, *Master of the (miss) Universe* (2001), which explored race, sexuality, and art, and was named “Best Bet” by the *Los Angeles Times*.

His novels were equally well-received and shined a spotlight on the community that, at an early age, he committed to give voice to. *Letters to Montgomery Clift* (2002), depicting the effects of the Marcos dictatorship on the lives of Filipinos in the Philippines and the United States, received many awards including the Stonewall Book Award (American Library Association), Violet Quill Award (Insight Out Books), the Global Filipino Literary Award (Our Own Voice), and the Gold Seal (ForeWord Magazine). He was honored with many additional nominations, including the PEN Center USA West Literary award, the Lambda Literary Award, and the Asian American Literary Award. His second novel, *Talking to the Moon* (2007), explored the devastating effects a hate crime has on a Filipino American family. *Talking to the Moon* was chosen as “LA Weekly’s Pick of the Week” and went on to become a *Los Angeles Times* Bestseller.

A tireless writer and creator, Alunit went on to pen more plays reflecting his experiences as well as an impressive body of short works, both fiction and nonfiction.

In 2012, at the age of 44, Alunit entered graduate school and in 2018, earned a Master of Divinity in Buddhist Chaplaincy. As an ordained Buddhist monk, he provides spiritual support to the LGBT community, a group historically and presently treated poorly by religion.

For his COLA Fellowship, Alunit will continue developing his novel, currently titled *The Valet*, inspired by (but not about) German Expressionist filmmaker F.W. Murnau. Murnau was a gay man making movies of unrequited love. Decades

**Born 1963,
Baguio City,
The Philippines
Lives and works in
Los Angeles, CA**

M.Div., University of the West,
Rosemead, CA, 2018

BFA, University of Southern
California, Los Angeles, CA

Novels

2007
Talking to the Moon, Burning
Page Press

2002
Letters to Montgomery Clift,
Macadam Cage

Plays

2002
Master of the (Miss) Universe

1998
*The Rice Room: Scenes from
a Bar*

1995
*Mr. and Mrs. LaQuesta Go
Dancing*

Selected Anthologies
and Short Stories

2005
Guest List Girls, Lodestar
Quarterly

2003
*The Dreams that Made Delya Ar-
raya Cavanaugh Weep*, Lodestar
Quarterly

2000
*Take Out: Queer Writing from
Asian Pacific America*, Temple
University Press

*Tilting the Continent: Southeast
Asian American Writing*, New Rivers
Press

before Stonewall, his work was considered by many to be the start of the gay liberation movement. In 1929, Murnau died in a car crash along the California coast with his Filipino valet at the wheel. The rumor had been that Murnau and his valet were romantically involved. It's a story that has persisted for decades. What struck Alunit about this rumor was the lack of attention paid to, or even curiosity about, the valet who survived the crash. The unnamed valet was never heard of again as he was, after all, just another Asian servant. In his novel, Alunit imagines the life of the valet, giving him agency, visibility, and voice after a century of Hollywood snickers that relegated him to stereotype and footnote.

Eduardo Santiago

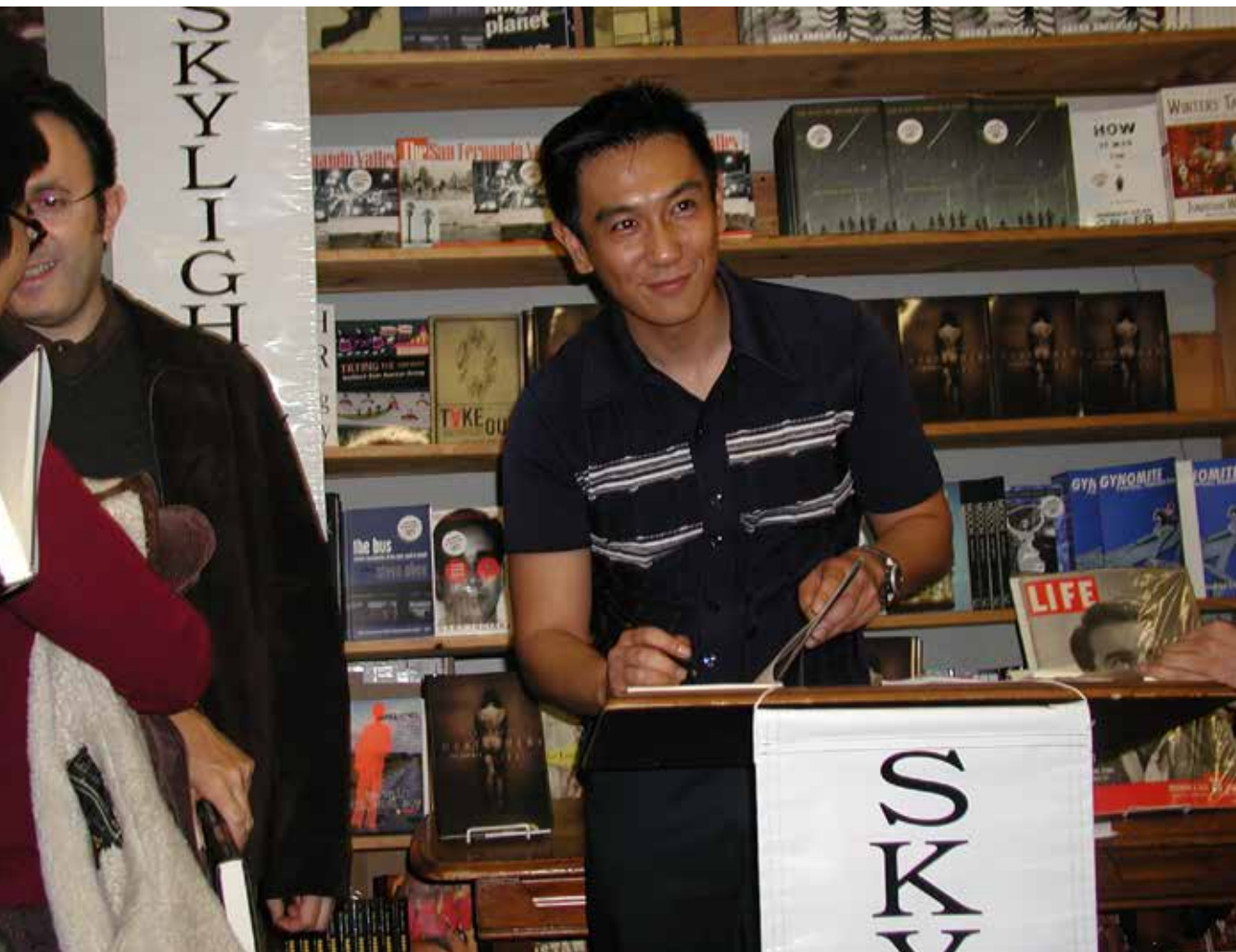

Book Signing at Skylight Books, Los Angeles, CA, 2002.



Still images from a reading of the new work titled *The Valet* performed for video-broadcast on site at Grand Annex, Los Angeles, CA. Photo: Josh Caffrey.



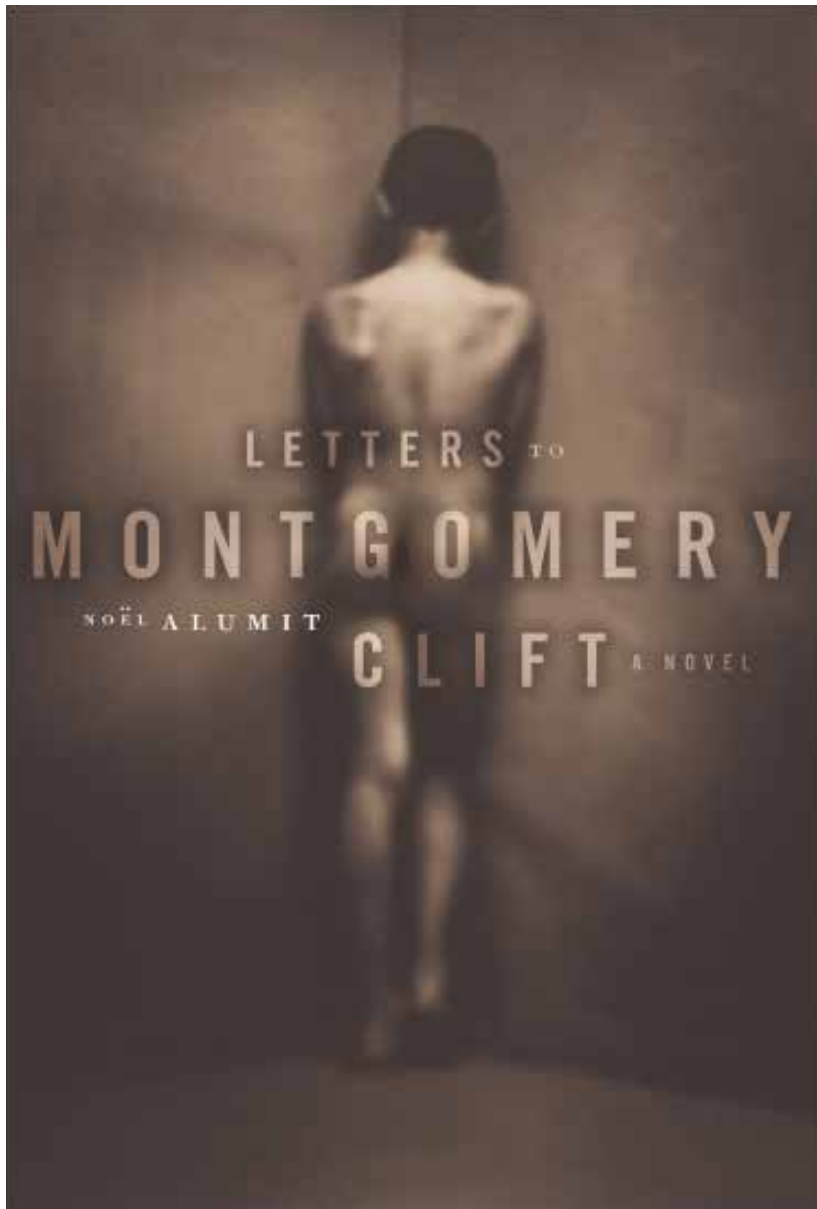

Letters to Montgomery Clift, 2002.
Macadam Cage, San Francisco, CA.

Documentation from *Master of the (Miss) Universe*, 2002. Photo: Michael Matson.

Documentation from *Master of the (Miss) Universe*, 2002. Photo: Michael Matson.

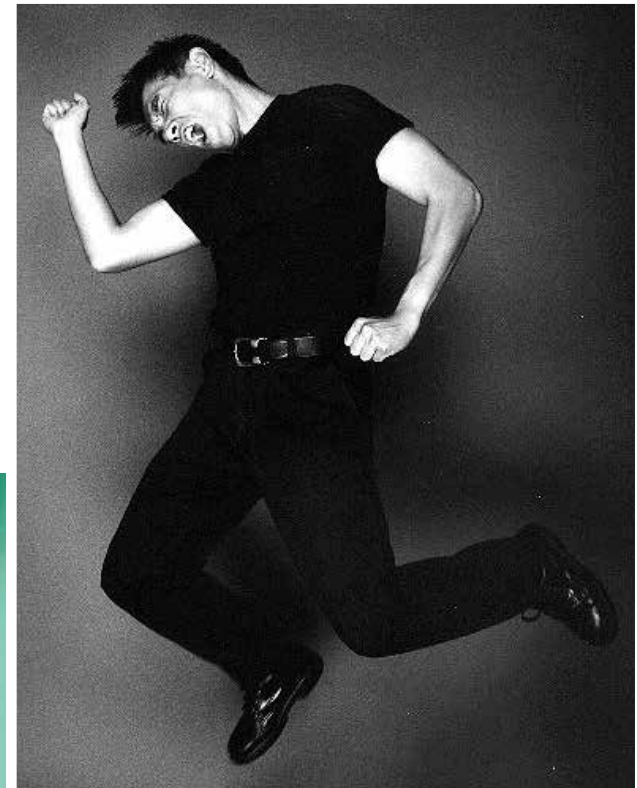



Edgar
Arceneaux

We gaze into a mirror that is, at the same time, not a mirror. Or rather, that was once a mirror: an everyday object made of silver nitrate applied to a glass substrate, protected with a layer of paint, designed to extend our view. But it is that no more. Stripped of its protective layer, the silver nitrate has been through a demanding

process that is both chemical and physical, grafted onto a new substrate—canvas—and the glass peeled away. The stresses of this procedure are registered on the surface we observe. Cracks and radial fractures, indices of impact, signal where the brittle glass has broken. Viscous paint seeps through where the transfer has slipped, producing weird eddies and crusts of reflective silver, black, brown and green. Rigidity cedes to fluidity; objecthood is decanted into a wildly impure—and indeed poisonous—visuality.

Mirrors have been a recurring figure in Edgar Arceneaux's work for the last 20 years. They cropped up in drawn form in his 2003 book *Lost Library* and served as a central metaphor for the refractions of memory in his installation *Drawings of Removal* (2003–04). Broken shards of mirror provided a surface for slide projections in his exhibition *Hopelessness Freezes Time* (2011–12) while a makeup mirror was a key prop in the artist's meditation on blackface in the play *Until, Until, Until...* (2016). Playing a different role in each case—standing for the fragmentation of knowledge, the slippages of memory, or the troubled formation of subjectivity—in each situation Arceneaux has seen them as crucibles within which culture is formed and subjects come to know themselves.

Shattered or whole, these earlier mirrors typically assumed a position within a constellation of artifacts drawn from various cultural imaginaries: pop culture, science fiction, the art history of the 60s and 70s, techno music, urban uprisings in Watts or Detroit, and the political and personal histories of the Civil Rights movement. In psychoanalytic terms, this idea—the imaginary—points to the role of images in uniting, and making-whole, the fragmented “body-in-pieces” of early childhood. In sociology it stands for the massive background consensus that shapes lived experience. Both ideas resonate powerfully with Arceneaux's practice. His work dwells on the cultural imaginary in order to show its workings and anatomize its pieces, and to make visible the broken or fragmented contents of our too-convenient—and in some senses, fraudulent—moral lessons and cultural narratives.

Within these ensembles, the mirror was a sign of this false unity. In broken form, it signaled the multiplicity, entropy and fragmentation atop which our cultural imaginaries are precariously constructed. A broken mirror, after all, cannot be repaired or restored.

What of Arceneaux's recent works? They present the mirror itself, removed from its imaginal ensemble of images or artifacts, and dislocated from the

**Born 1972,
Los Angeles, CA
Lives and works in
Los Angeles, CA**

Education	2019 <i>Boney Manilli</i> , Lagos Theater Festival, Nigeria	Public Collections
MFA, California Institute of the Arts, Valencia, CA, 2001	Selected Exhibitions	Museum of Modern Art, New York, NY
Fachhochschule Aachen, Aachen, Germany, 2000	2021 <i>Untitled</i> , Galleri Opdahl, Stavanger, Norway (group)	Whitney Museum of American Art, New York, NY
BFA, Art Center College of Design, Pasadena, CA, 1996	<i>Permanent Collection</i> , Museum Ludwig, Cologne, Germany (group)	Ludwig Museum, Cologne, Germany
Selected Performances	<i>Untitled</i> , Nevada Museum of Art, Reno, Nevada (group)	The Pompidou Center, Paris, France
2022 <i>Boney Manilli</i> , Susanne Vielmetter Los Angeles, Los Angeles, CA	2018 <i>Library of Black Lies</i> , Henry Art Gallery, Seattle, WA (solo)	http://studioedgararceneaux.com
<i>Boney Manilli</i> , Center for the Art of Performance, UCLA, Los Angeles, CA	<i>Edgar Arceneaux</i> , Yerba Buena Center for the Arts, San Francisco, CA (solo)	

physical conditions that made it a useful optical prosthesis. Instead, these grafted and traumatized ex-objects venture toward the *informe*. In the process they develop a new rhetoric within Arceneaux's practice of uncanny embodiment. Half-hidden paintings of unidentified bodies insinuate themselves from beneath shredded mirror-skins. Calling to mind death shrouds and amniotic sacs, they are perhaps Arceneaux's first works to move beyond history, and beyond images.

Julian Myers-Szupinska



Process detail from the *Mirror Pull* series, 2021–21.
Silver nitrate and acrylic on canvas.

Mirror Pull # 2, 2020.
Silver nitrate and acrylic on canvas. 40 x 33 inches.



Untitled, 2021.
Silver nitrate and acrylic on canvas.
40 x 33 inches.



Untitled, 2021.
Silver nitrate and acrylic on canvas.
60 x 108 inches.



**Maura
Brewer**

When people ask me what I do for a living, I often say that my entire profession exists to launder money for rich people. From early systems of patronage to more contemporary notions of “art-washing,” art has long been a means for the wealthy to transform their wealth into something else: legacy, cultural capital, or public good will. Most

artists come to this knowledge somewhat belatedly through institutional critique, critical theory, or activism. We learn that our world is structured by the cultural and financial priorities that serve this system; yet we experience such value as if it descends from on-high, articulated through transcendental terms like “merit” which obscure their social and material formulation. Even after we come to know that we are the matter, the instrument, the substrate of capital circulation, we remain entirely bypassed by that very system that mobilizes us, the system for which our work is the alibi. To invert an ecclesiastical model of knowing, most of us who work in the art world eventually come to learn that even though we are of money laundering, we are not *in* it.

Maura Brewer’s essay film *Rosy* is an interrogation of how enormous amounts of wealth get sublimated into culture. Yet it is not another systemic analysis of how and why this happens. That kind of “making visible” of the secret power, secret money, secret violence, etc. that constructs our universe is thrilling at first, then comforting for a while as a kind of intellectually-affirming paranoia. But eventually, we all come to realize that merely *knowing* reveals nothing. Through an attention to the double-narrative that structures her source material, Jess Bond’s 2018 “psycho-sexual thriller” *Rosy*, Brewer’s film asks us to consider a much more difficult set of questions: How do we feel, and perhaps even face, our minor role in a system that overwhelms us? As Brewer’s deft editing and narration makes clear, Bond’s film tells two stories. One is a pseudo-feminist narrative of female empowerment that Bond is telling herself, where a beautiful actress negotiates the power and violence of men. The other is the real one, which is about failed career ambitions, privilege and entitlement that never took. This alone would be compelling, though Brewer’s work adds another twist of context: Jess Bond, formerly Jessica Manafort, is the daughter of Paul Manafort, the now-pardoned Republican Party campaign consultant convicted of fraud. She makes this film in the wake of her divorce from Jeffrey Yohai, a property developer also convicted for fraud. It’s therefore possible that her films, funded at first by her father and then perhaps her husband, were a vehicle for specific instances of money laundering rather than its general condition. In which case she achieves something most of us only gesture toward: her work is actually a crime.

It doesn’t seem that Bond knows. Yet knowing here is not the point. There’s something else that erupts in Brewer’s *Rosy*, a heartbreaking story of an artist’s career disappointment shrouded in a female empowerment cliché. Brewer approaches this subject with empathy and the slippage of first-person identification tells us a story about the thinness of the world we live in, the regular conspiracies of capitalism we negotiate, and ultimately the sustenance that comes from just making good work in a system not meant for you. It’s this latter consolation that

**Born 1984,
Portland, OR
Lives and works in
Los Angeles, CA**

Education	2017 <i>Items: Is Fashion Modern?</i> MoMA, New York (group)	www.maurabrewer.com
MFA, University of California Irvine, Irvine, CA, 2011	2016 <i>Jessica Chastain</i> , The UAG, Uni- versity of California, Irvine (solo)	
BFA, School of the Art Institute of Chicago, Chicago, IL, 2006		
Selected Exhibitions	Selected Bibliography	
2021 <i>Integration</i> , The Canary Test, Los Angeles, CA (solo)	Bartlett, Djurdja. “The Con- structivist Sartorial Utopia and Its Revolutionary Potential.” <i>The Oxford Handbook of Communist Visual Cultures</i> , 2020.	
2019 <i>A History of Counter-Fashion</i> , Museum of Arts and Design, New York (solo)	Radke, Heather. “The JUMPSUIT That Will Replace All Clothes For- ever,” <i>The Paris Review</i> , 2018.	
2018 <i>Cultural Uniform</i> , Art in General, New York, NY (solo)	Carson, Juli. “Dora Chastain,” UAG Gallery, UC Irvine, 2016.	

is so obviously missing from the original *Rosy*. As revealed in texts with her sister, Bond understands that her movie isn't great—and yet maybe doesn't realize why. She blames the fact that her money had run out, that she couldn't cast bigger stars in leading roles, but those are of course not the reasons. This is where Brewer's film does something remarkably generous. Brewer gives her own good work to the original through the gift of her re-edit. In Brewer's *Rosy*, she identifies the original film to be an unintentional reveal of how the external conditions of capitalism match the way we feel inside—or, to use a literary term, is a pathetic fallacy. A woman is being trapped somewhere. A façade of wealth is collapsing. And yet, it is still possible to be an artist. All you have to do is make art.

Aliza Shvarts





1550 Blue Jay Way, 2021.
Video still.



The Surface of Mars (installation view), 2016.
Single-channel video, color, sound. 12 minutes
31 seconds. Photo: Jeff McLane. Courtesy of
University Art Gallery, UC Irvine.



Nao
Bustamante

Bloom is not a speculum but a speculation.

**With this work, Nao Bustamante re-imagines
this most unpleasant gynecological utensil.**

**Bustamante inserts herself into feminist
canon—a constellation of artists making**

very vaginal work, a cunt art star map on which you will find Georgia O'Keefe's flowers and Annie Sprinkle's oracular displays.

Russian revolutionaries argued for design as a crucial vector for expanding the people's access to utopian possibility. Communism, in this view, could be expressed in the design of everyday life—the project of dismantling Capitalist systems of wealth accumulation begins with the re-design of a teapot. Artists exploring feminist aesthetic possibilities enact similar attacks on the world: the systems of power that disenfranchise us, that alienate us from our own bodies, express themselves in the forms of the instruments we use, and that are used on us.

The speculum used in over 50 million annual pelvic exams in the U.S. alone approaches the vagina as if it were a broken garage door. It cranks you open. Everything about it is awful: its look, its texture, the sound it makes, and the history of its making.

This device was refined and patented by J. Marion Sims, often heralded as the "father" of American gynecology. He developed the tools of his trade while experimenting on enslaved women. He honed his practice on these women, who had suffered through difficult childbirth and who did so in a context in which their pregnancies were gifts not to their families, but to their masters. The healing of these mothers serviced the people invested in their reproductive potential. Once he figured out how to repair tears in the fabric of these women's lives, Sims applied his expertise to the healing of white women.

In his autobiography he describes himself as a reluctant expert—"If there was anything I hated," he wrote, infamously, "it was investigating the organs of the female pelvis." This device captures that posture towards the pelvic region. Frequently described as not having been designed with patient comfort in mind, the speculum is a prop in a theater which renders the vagina into an unfeeling obstacle. The exile of the story of vaginal sensation from gynecological treatment is particularly forceful where bodies are Black and Brown: doctors are notorious for ignoring the pain of patients who are not white. Those forms of racism amplify and redirect a hostility—an anger—which collects around this part of the body from which we all emerge. On the table, we feel this.

Driving home from an annual exam, the artist began to rewrite and reimagine the story.

What if the scene of the gynecological exam were choreographed differently? What if it was more like a day at the spa? What if the erotics of opening up the body were not something that was managed and disavowed by white sheets thrown over your legs and a promise of doctor and patient to not look each other in the eyes? What if the device used to open the body up were something you *wanted*

**Born 1963,
San Joaquin, CA
Lives and works in
Los Angeles, CA**

Education

Honorary Doctorate, San Francisco Art Institute, San Francisco, CA, 2020

BFA/MFA (combined), San Francisco Art Institute, San Francisco, CA, 2001

Selected Exhibitions

2019
Autentika, Sculpture Quadrennial, Riga, Latvia (group)

2017
Teach Me Spanish / Enseñame al Español, The Broad Museum, Los Angeles, CA (group)

2016

Silver and Gold, Museum of Modern Art, New York City, NY (solo performance)

2015

STEP AND REPEAT, Museum of Contemporary Art, Los Angeles, CA (solo performance)

Soldadera, Vincent Price Art Museum, Los Angeles, CA (solo)

Selected Bibliography

Miranda, Carolina, "Femininity in Kevlar: Nao Bustamante's women of the Mexican Revolution," *Los Angeles Times*, 2015.

Muñoz, José Esteban, "The Vulnerability Artist: Nao Bustamante and the Sad Beauty of Reparation," *Women & Performance: A Journal of Feminist Theory*, 2006.

www.naobustamante.com

to touch you. What if this something caressed you, and was like a hand but more than a hand? What if a pelvic exam was experienced as a form of therapeutic body work, or a spiritual ritual? Many healers have and continue to approach sex parts as holy portals. Sexual health has been and is held in community; sexual knowledge has been and is treasured. And a few healthcare practitioners have been offering up alternate models—scopes which glide along and illuminate the body's canal. These new instruments are much preferred by the patients who have been lucky enough to experience them. But doctors in this male-dominated profession are used to and comfortable with the speculum and the system for which it stands. Visionaries like Bustamante are retooling our instruments and imagining a radically different environment in which we will use them.

Jennifer Doyle



Fighting Costumes, Kevlar Rebozo, and Soldadera (installation view), 2015. Dimensions variable. Photo: Branden Hollis.



Given Over to Want, 2019. Cotton sheets, wine, flowers, cigarettes, oranges, tape. Dimensions variable. Photo: Lauris Aizupietis.

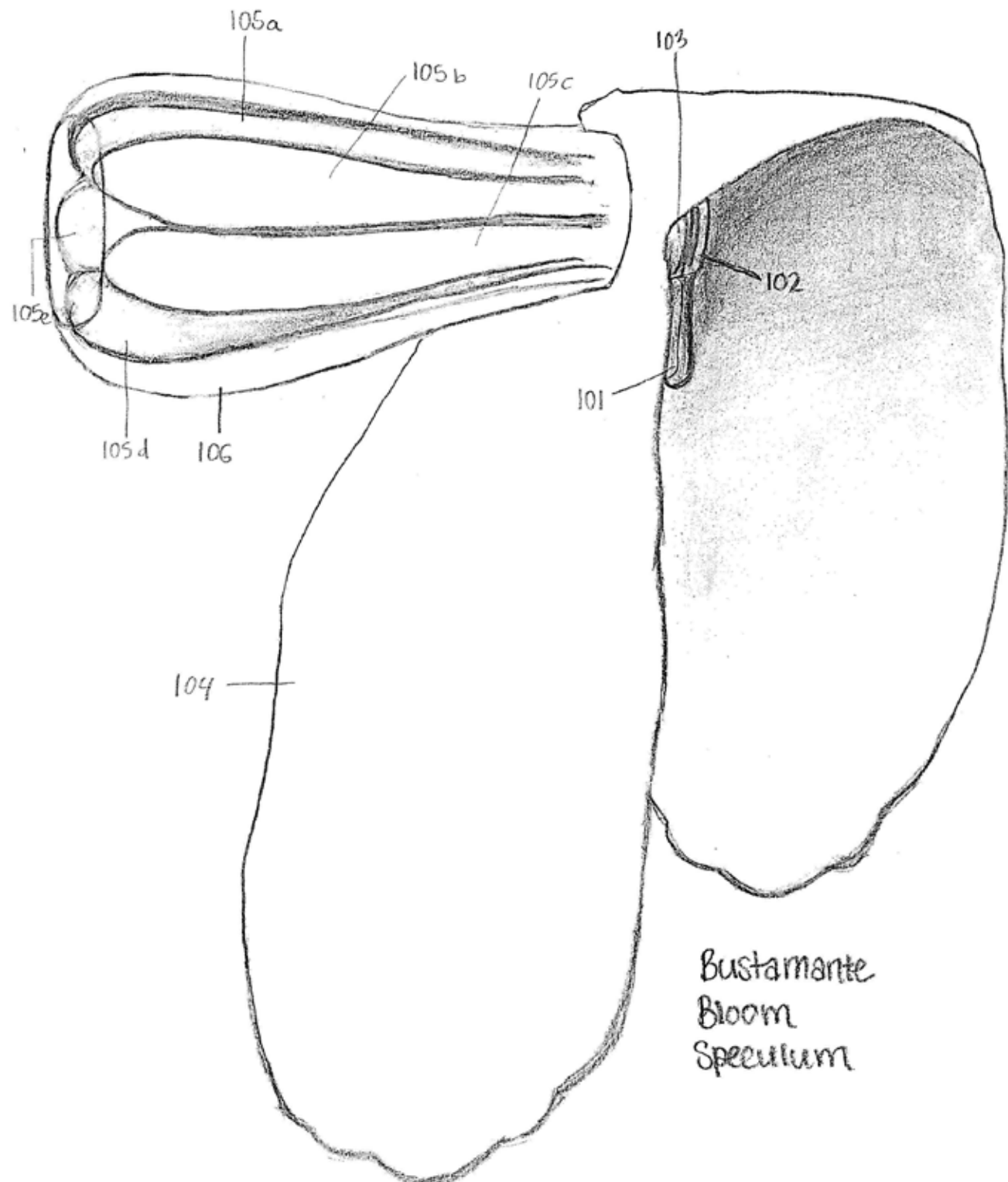

Bustamante
Bloom
Speculum

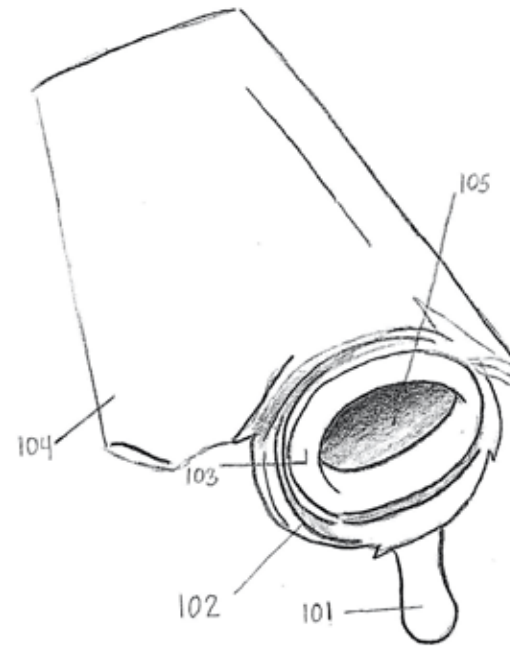

Bustamante Bloom
Speculum

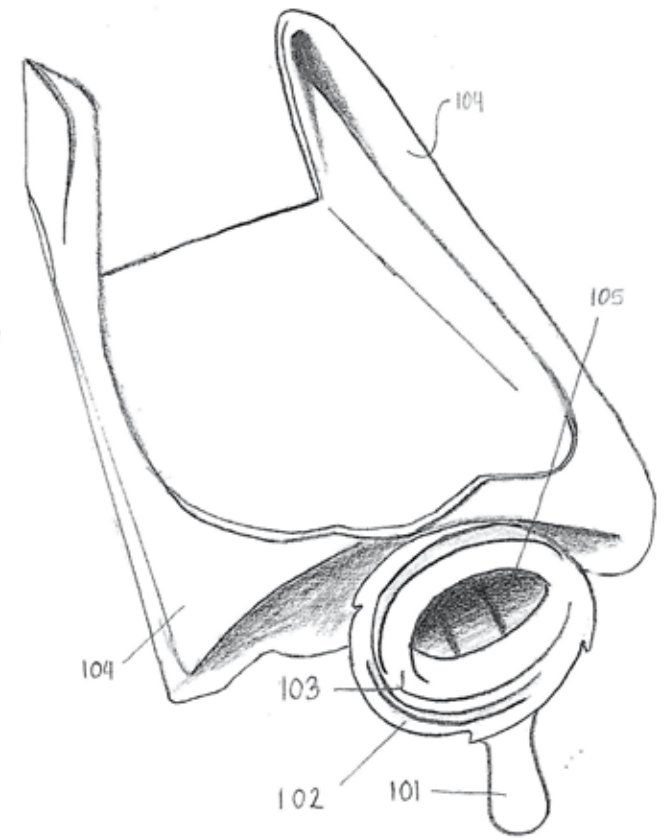



Jedediah
Caesar

Jedediah Caesar’s peripatetic career sometimes seems to circle a single question: what is a *thing*? It’s a question made famous by Heidegger, who opens his answer with a nervous joke (borrowed from Plato) about Thales and the Thracian housemaid. Thales is walking while looking upward, contemplating the heavens. He falls into a

well; the housemaid laughs. The great thinker can’t even see the things “in front of his very nose and feet.”

Caesar’s work is decidedly concerned with the things in front of our noses and feet; his view is the housemaid’s as much as Heidegger’s. He follows a tradition of sculpture interested less in making idealized forms than in revealing particular human relations. Thus when his work seeks monumentality, it pursues not grandeur but quotidian presence, as in *Gleaner Stone* (2007–8), a public sculpture that cast street refuse in a giant block of resin—immovable, but still human in scale. When it addresses materiality, it treats material not as generic substance made specific by the sculptor’s hand but as a conditional property expressed by each thing in its time and place, as in the combined plastic foam, heavy metals, and spices in the 2013 exhibition “out where the stones grow like roses.” When it aims for beauty, it’s liable to find it in kitsch as much as in refinement, as in the Florida quarry stones dyed with the Day-glo colors of tourist souvenirs in “Stone Underground” in 2015. When it reaches for distinction, it deploys the syncretic and the ersatz rather than the pure, as in his imagining of the colorful currency of invented “micronations” for the show “Rozoj” in 2013.

In each case, Caesar unearths, sometimes literally, the physical things, found or made, through which human beings establish meaning by shifting conventions of attention. To see the things that are right in front of us—to peer down the well, as it were—is to see, and even to constitute, our relations to ourselves, each other, and nature. Distinguishing things in a mind or a community from the undifferentiated flux of experience is human nature, but the varying scales of biological and geologic Nature recapitulate that transit between moment and time, consciousness and cosmos. Thus Caesar’s fascination with fossils and rocks. His interest is not scientific, however, but economic and spiritual; his things almost always refer to vessels or currency, invested with ritual communication and cultural exchange, both between people and with the divine. Thus the coins and votive offerings. His regard is not ironic but ecumenical, exuberant, humane—like an anthropologist in love with his subjects. The only authority is that of form, rather than principle, or price, or propriety. He likes scavengers and forgers, numismatists and tchotchke-mongers, enthusiasts and amateurs, as much as he likes professional craftsmen and artists. Recent work has strayed far from the form of sculpture, even, focusing on religious sites and oral histories, broader formal definitions of thing that nonetheless locate meaning.

Caesar’s insistence on the human scale of things both reduces and enlarges the role of the artist; the artist cannot be more heroic than the ordinary person, but neither can he be less. An artist’s process of looking generated what

**Born 1973,
Larkspur, CA
Lives and works in
Los Angeles, CA**

Education	2015 <i>Stone Underground</i> , Locust Project, Miami, FL (solo)	Selected Bibliography
MFA, University of California, Los Angeles, CA, 2001		Diehl, Travis, “Concrete Island’ at Venus, Los Angeles,” <i>art agenda</i> , 2017.
BFA, School of the Museum of Fine Arts, Boston / Tufts University, 1999	<i>UNEARTHED: Found + Made</i> , Oakland Museum of Californian Art, Oakland, CA (solo)	Chang, Ian, “Jedediah Caesar at Susanne Vielmetter Los Angeles Projects,” <i>Frieze</i> , 2013.
Selected Exhibitions	2011 <i>Soft Structures</i> , Museum of Fine Arts, Boston, MA (solo)	Hutton, Jen, “Review: Made in Space, Night Gallery, Los Angeles,” <i>Art Papers</i> , 2013.
2018 <i>A Matter of Course</i> , Guggenheim Gallery, Chapman University, Orange, CA (group)	2008 <i>Whitney Biennial</i> , Whitney Museum of American Art, New York, NY (group)	Trigg, Sarah, “Studio Life: Rituals, Collections, Tools, and Observations of the Artistic Process,” <i>Princeton Architectural Press</i> , 2013.
2016 <i>Overgrowth</i> , DeCordova Museum and Sculpture Park, Lincoln, MA (group)		

looked like a truck full of mundane detritus, in *Brighthotdaylongdarknight* (2008), but that pick-up was still full to the windshield with implied significance, evidence of intentional wandering. If his practice allies with folk traditions of totem and talisman more than high-art creation, his philosophy recalls a less Continental lineage than Heidegger's as well, something more American and democratic, maybe Transcendentalist.

"A thing for Thoreau," literary scholar Branka Arsi has written, "is organized less by its form or usage, by its solidity or impenetrability, than by the intense relations in which it dwells and through which it moves, relations capable not just of reshaping past into future but also of enacting marvelous exchanges between what is and what isn't human." Thoreau himself, in his journal, advises us to "be not long absent from the ground." Caesar's things, like Thoreau's, become an entire politics, an economy, and a cosmology—just by keeping their eyes on that ground.

Ian Chang

Sovereign/ snakestone, 2015.
Quarried oolitic limestone (keystone),
commercial printing pigments.
55 x 27 x 36 inches.



brighthotdaylongdarknight (detail), 2008.
Collected objects, truck. 108 x 54 x 65
inches.

brighthotdaylongdarknight, 2008.
Collected objects, truck. 108 x 54 x 65
inches.



Wunderjammer, 2018.
Egg shell, stone, seashell, coral, sand, epoxy.
4 x 4 x 6 inches. Photo: Jeff McLane.



Hauser Bed Document: An anomaly strikes a hole in space, 2016. Archival pigment print.
10 x 15 inches.



Rozoj (detail), 2013.
Sand, pigment, urethan resin, polyester resin,
pewter, wood. 30 x 36 x 3 inches. Photo:
Robert Wedemeyer.

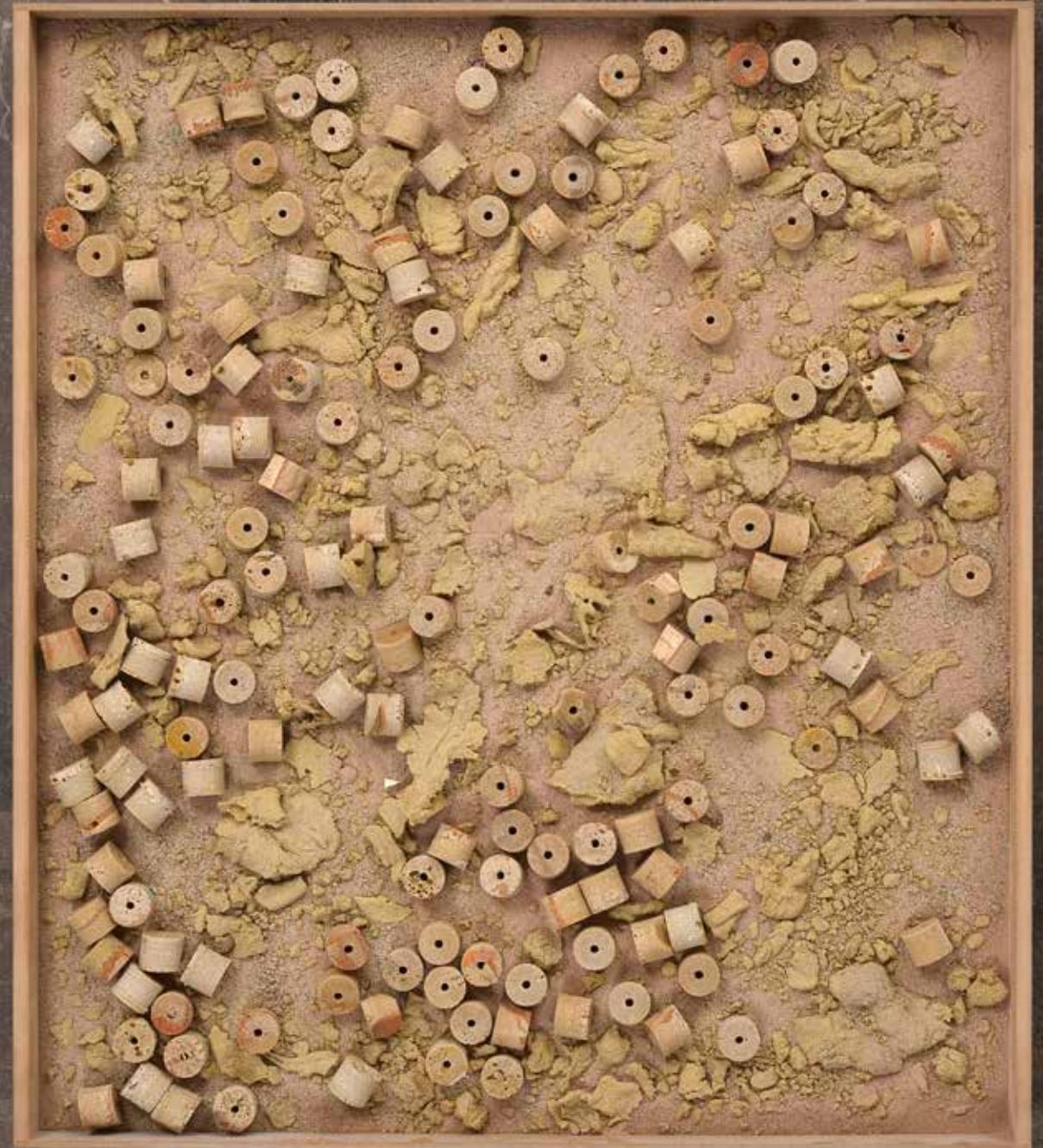



Neha
Choksi

***Strata bouquet (uncertain allies)* makes reference to Neha Choksi's embodied personhood, in only the oblique way that all art objects refer back to their artists. Choksi's ongoing engagement with rock, stone, and the processes of extraction allow us to witness her interactions, holding, throwing, and kicking the material.**

Evidence of these acts can be read like handprints. Here, the invisible forces of tension and gravity, weight and balance, are at first more evident than the artist's labor. The artist's mark is the existence of the art object itself.

Choksi's installation emerges from a correspondence of material, physics, and rhythm. Seven tall canvases of slightly differing widths hang on the wall in stately formation. However, they escape categorization as "only" paintings or wall works: each canvas has a corresponding boulder placed several feet in front of it. These are connected by two elements: canvas straps, stretched taught at an angle, and steel strips, which lay flat on the ground. From each of the seven boulders, seven cylinders have been hollowed out with the extracted material used to make corresponding sets of pigments that color the straps and canvases. Each strap has been moved one panel to the right and passes through the cored holes, creating a visual and physical cohesiveness that plays with color and form, separation and connection. The widths of the straps have also determined the spacing of the canvases while the pigments made from crushing the extracted stone have been enhanced with other natural materials from the earth to mimic the color of the boulders. These illusionary interventions by Choksi disrupt simplistic divisions between nature and culture, the given and the made. The contrast of the straight lines of the canvas with the rough forms of the boulders similarly call attention to these binaries only to dispel them. The artist's body relies on time to make marks on these stones, just as the earth does.

This installation is a conceptual variant from Choksi's other work with stone, given that specifics of geographical origin are less important than their diversity of material, age, and location. Sourced across the United States, the different types of rocks are the result of disparate raw elements, earthly processes, and geological lifetimes. Human systems then make it possible for such boulders to exist for purchase, thus beginning their recognized entry into the realm of culture. The title—*Strata bouquet*—denotes this collapsing of time, space, and scale made possible by multiple interventions. The word *stratum* first emerged in the 16th century—in the age of Dutch painted still lives implied by Choksi's use of bouquet in the title—meaning to layer or cover, that is, a gesture performed. The etymology of the word constitutes a collapsing in itself, with *strata* containing simultaneous meanings established at various historical moments, pertaining to geology, surfaces and structures, social categorizations, and statistics.

The world increasingly bears the burden of our demands and our gaze. With this in mind, Choksi disturbs our assumptions regarding the organic and the manufactured by penetrating the solidity of a rock. Her pulverization of stone results in a slippage from nature to culture. Materially speaking, a painting is just pigment and art production demands the extraction of matter. In the dynamics of probing and

Lives and works in Inglewood, CA and Bombay, India

Education

MA, Columbia University, New York, NY, 2000

BA, University of California, Los Angeles, Los Angeles, CA, 1997

Selected Exhibitions

2021
Uncertain Allies, Kleefeld Contemporary Art Museum, Long Beach, CA (solo)

2018
Elementary, 18th Street Arts Center, Santa Monica, CA (solo)

Made in L.A. 2018, Hammer Museum, Los Angeles, CA (group)

2017

Faith in friction, Manchester Art Gallery, Manchester, UK (solo)

Liberty Matter, Commonwealth and Council, Los Angeles, CA (solo)

2016

The Future is Already Here—It's Just Not Evenly Distributed, 20th Biennale of Sydney, Sydney, Australia (group)

2015

Minds to Lose, Hayward Gallery Project Space, London (solo)

Selected Bibliography

Biswas, Allie. "Neha Choksi: Transformations necessitate lost pasts and renewals of future hopes," *Studio International*, 2017.

Dworkin, Craig. "We are all meat, striving to be human," *ART India*, 2015.

Chong, Sei. "Indian Artist Explores Absence Through Presence," *The New York Times*, 2013.

www.nehachoksi.com

making, reflection and representation, there exist the possibilities of both parasitism and reciprocity. Given this, what kind of allies can we, as artists, makers, and humans, be to the earth?

Ana Iwataki

Dust to Mountain (video still), 2016.
4K video installed on wedge at the angle of the artist's kick, sound, sheer fabric curtains. Dimensions variable, installed each time with unique curtain configuration.

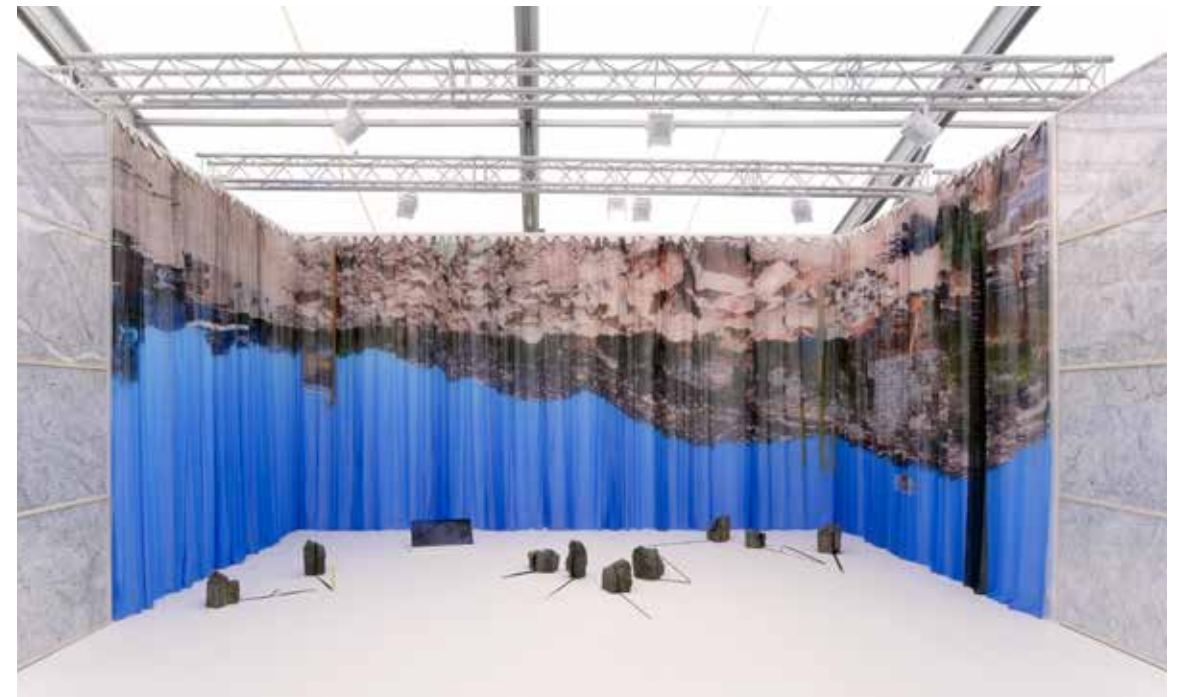

Stone Breath Mountain Dust (installation), 2016.
Multimedia installation, Frieze, London.
Dimensions variable. Photo: Andy Keate.

The Weight of the Cave, (detail), 2016–2019.
Pulverized rock paint on hickory creek granite boulders. Dimensions variable.
Photo credit: Brica Wilcox.





Strata bouquet (uncertain allies), 2021.
Boulders, canvas, pulverized rock pigment,
earth pigment paint, stainless steel.
96 x 123 x 35 inches. Photo: Ruben Diaz.

Strata bouquet (uncertain allies) (detail), 2021.
Boulders, canvas, pulverized rock pigment,
earth pigment paint, stainless steel.
96 x 123 x 35 inches. Photo: Jake Courtois.



Strata bouquet (uncertain allies) (detail), 2021.
Boulders, canvas, pulverized rock pigment,
earth pigment paint, steel.
96 x 123 x 35 inches. Photo: Ruben Diaz.



**Michael
Datcher**

Michael Datcher has for a quarter-century, been among our leading minds on all matters American, most specifically, the multifaceted Black American experience. Working in a variety of mediums, Datcher has influenced generations of thinkers. As such, it is impossible to neatly summarize either his cultural and artistic impact or his varied

and diverse achievements. With the mediums of memoir, novel, academic scholarship, TV, and radio, Datcher has explored himself and the Black world around him and through that exploration, he's chronicled complex realities vital to America itself. Implicit in his tireless truth work is the understanding that only through deep searching and an open, vulnerable reckoning can healing and real change ever occur for individuals, communities and for our country.

Raised in East Long Beach, California in the 1970s, Datcher traversed gang territories as a youth during an era when local gang-related violence had reached a dangerous nadir. The popular cultural production that came of that calamitous world is now well known, from the rise of West Coast hip-hop music to films such as *Boyz n the Hood* and *Menace to Society*. Less remembered is the Los Angeles-Long Beach literary renaissance that arose in the late 1980s and that spanned across the next decade; Black and Latinx writers, Datcher among them, made sense of their circumstances with the detail and depth that only literature can provide. At the time of its publication, Datcher's memoir, *Raising Fences*, elevated and expanded the national discussion around urban crisis and Black male identity. Datcher's unflinching examination of his upbringing is in the tradition of the Black American memoir that begins with the slave narratives and connects to our greatest writers and cultural figures, from Frederick Douglass to W.E.B. DuBois, Richard Wright to Malcolm X and Maya Angelou, Margo Jefferson to Michelle and Barack Obama. Yet in the specifics of its story, *Raising Fences* is a definitional example of late twentieth century Black male experience.

Datcher's novel *Americus* indicates his range. Set in late nineteenth and early twentieth century East Saint Louis, Illinois and bounded by the historical flash points of the Chicago World's Fair and the East Saint Louis massacre, the intergenerational family saga explores one family's inheritance of racial trauma and child sexual abuse. *Americus* and *Raising Fences* sit at opposite sides of a century, forming a powerful, dire vision of Black America, while Datcher's *Animating Black and Brown Liberation: A Theory of American Literatures* foregrounds the linked legacies of Black and Latinx written works across that same period, and into the new millennium. While Black-White relations are often emphasized in our media landscape as an amelioration of the foundational sin of transatlantic slavery, deeply under-discussed is the connection between Black and Brown history, politics, and artistic and literary production. That Datcher is a lifelong Californian is vital here, for it is in this state that Black-Brown bonds are longest, deepest, most intimate and enduring. Given this intertwined legacy and the changing demographics of America, Datcher's scholarship is very likely to achieve increasing prominence as time goes on and the academic

**Born 1967,
Chicago, Illinois
Lives and Works in
Los Angeles, CA**

Education	2019	2014
Ph.D., University of California Riverside, 2016	"Americus: A Novel," Kentucky Book Festival, Lexington, KY	<i>Americus: A Novel</i> , Third World Press
MA, University of California Los Angeles, 1994	"Shared History: Love, Obsession & Mystery in Historical Fiction" Panel, Louisiana Book Festival, Baton Rouge, LA	2001 <i>Raising Fences</i> , Penguin Putnam/Riverhead
BS, University of California Berkeley, 1992	"Can Literature Change Everything" Panel, Brattleboro Literary Festival, Brattleboro, VT	1999 <i>Black Love</i> (editor), Beyond Baroque Books
Selected Presentations	"The Craft of Fiction" Panel, Leimert Park Village Book Fair, Los Angeles, CA	1997 <i>Tough Love: Cultural Criticism and Familial Observations on the Life & Death of Tupac Shakur</i> (co-editor), Kwame Alexander
2020 "Resistance Literature," Marlboro College, Marlboro, VT	Selected Writings	www.michaeldatcher.com
"Global Black Studies" Roundtable, Modern Language Association, Seattle, WA	2019 <i>Animating Black and Brown Liberation</i> , State University of New York Press	

mainstream catches up to this revelatory area of study.

Today, Datcher is perhaps best known for his work off the page. As co-host of 90.7 KPFK's *Beautiful Struggle* public affairs news magazine, he's broadcast issues of import to Black and Brown Southern Californians for years, highlighting local thought leaders and providing a platform for activists. Rather than cloister himself in intellectually disconnected environs, Datcher has continued to elevate discussion in the public sphere at a moment marked by right-wing, racist revanchism, the galvanizing Black Lives Matter protests of 2020, and the root shock of COVID-19. As such, Datcher speaks to a public far beyond those who read books or navigate university campuses.

Across eras and mediums, yet centered on California's most critical edge, Michael Datcher has illumined and unsparingly explored Black American experience for multiple generations of readers and listeners. His work has elevated and diversified our national discussions around issues core to our American experience. His vast oeuvre will continue to impact literature, academia and Black intellectual space well beyond our present moment.

Dr. Keenan Norris

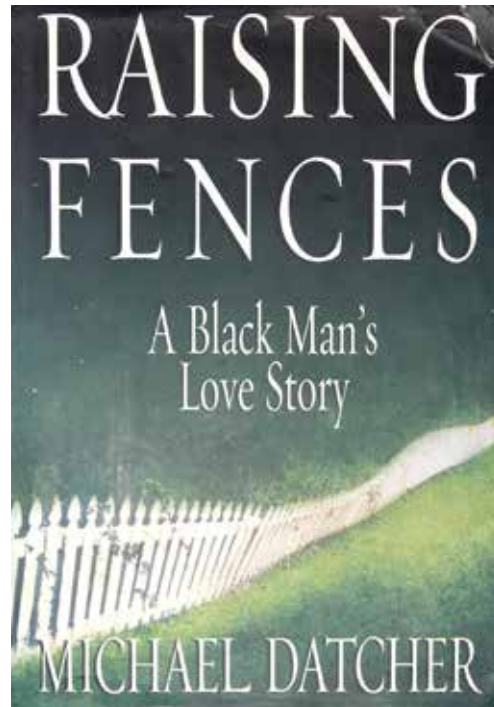
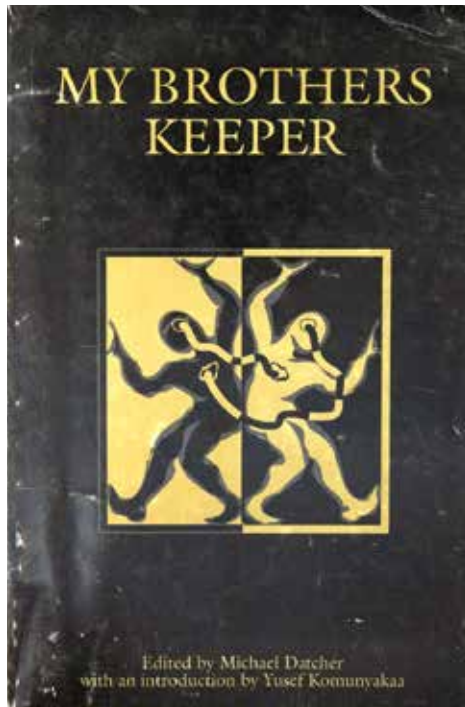

My Brother's Keeper (editor), 1992.
Self-published.

Raising Fences: A Black Man's Love Story, 2002.
Riverhead Books, New York, NY.

Still image from a reading of the new work titled *CULT* performed for video-broadcast on site at Grand Annex, Los Angeles, CA. Photo: Josh Caffrey.



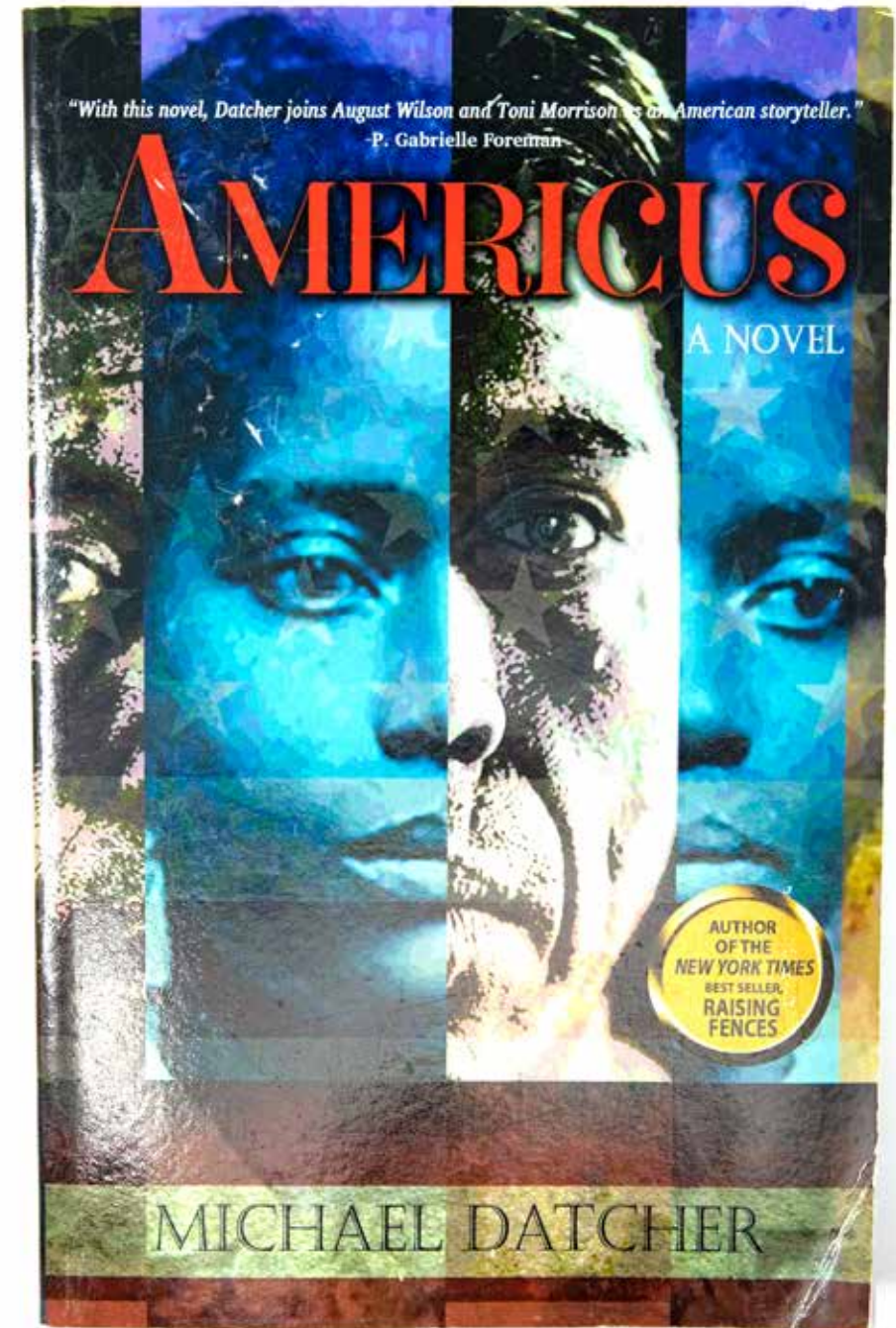
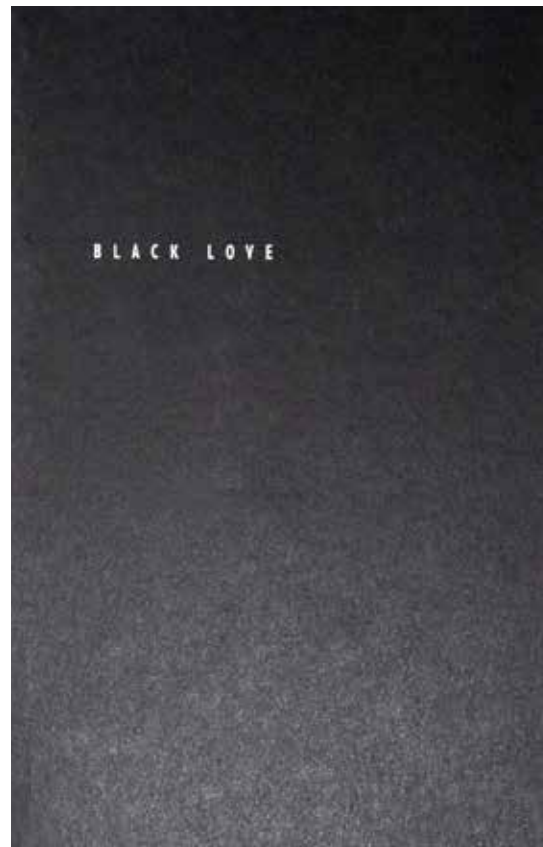
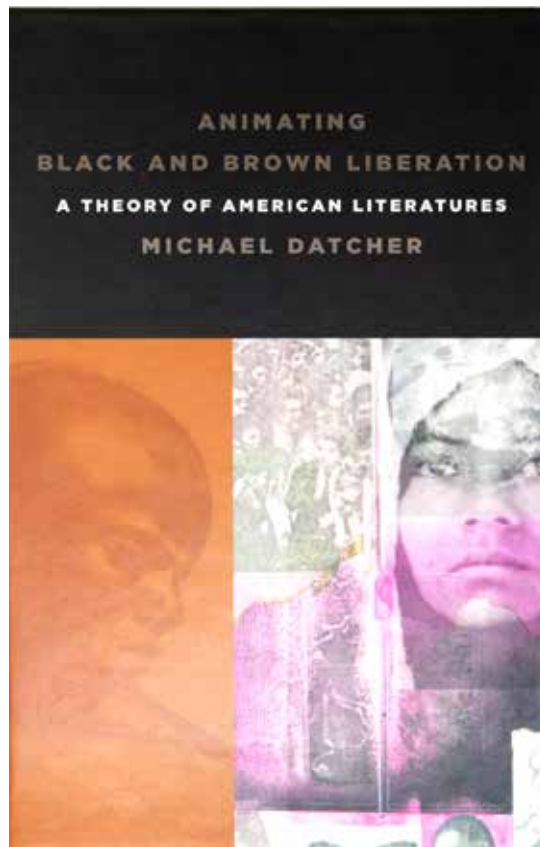

Animating Black and Brown Liberation: A Theory of American Literatures, 2019.
State University of New York Press, New York, NY.

Black Love (editor), 1999.
Beyond Baroque Foundation, Venice, CA.



Sarah Elgart

Sarah Elgart is a ferociously committed dancer, choreographer, and filmmaker. Her vision includes highlighting scale and painting space with media, movement, and singular visuals. Her works unfold like choreographed battles that winnow and exact revenge on social hierarchies through the sensual, gestural, and

expressive grammar of the body. Whether at Van Nuys bus platforms, in elevators and parking garages, on scissor lifts accessing runways at Los Angeles International Airport, or with the site-specific occupation of a New York City skyscraper, she imbues space with the fluid elegance of formal dance cut with the controlled chaos of ritualized, everyday gesture.

From a duet with a helicopter on a rooftop in downtown L.A., wrapping her body around glass and concrete in a daring juxtaposition of bone and muscle, or unfurling bodies out of black plastic petroleum bags, I have followed Sarah's work from both outside and in. I've been privileged to work with her as a performer, most memorably in *Zoo* (1992), a spectacle performed across streets and stages, in which Old World orders were depicted with giant puppetry and an army of dancers. I've witnessed how Sarah disrupts the everyday to empower others through movement, thought and beauty to exact the right proportion of hope.

I first witnessed Sarah's work in *Eleventhour*, a dance about the fear and frenzy of the AIDS epidemic. Her startling metaphoric image of glass shards punctured through a dancer's body drew me into her world. Utilizing dance as a platform for social justice, her inquiry into issues affecting marginalized communities propelled her work with women inmates, at-risk youth, transitional homeless women, and others. She founded La Boca Performance Space at the Sunshine Mission Casa de Rosas, one of L.A.'s oldest homeless shelters, and created MADRES (Mothers and Daughters Reaching Empowered States), a project made in collaboration with residents of the mission committed to the idea that performance equals empowerment. Under Sarah's direction, the women explored issues of homelessness, the L.A. riots, and adapted poetry about infanticide by Bertolt Brecht, all within the 100-year-old chapel turned creative space of La Boca. As a collaborator in this work, I witnessed how performance could help the marginalized identify the embedded pain in their lives and bring agency in establishing their own identity. Beyond La Boca, MADRES performed for major venues including the Mark Taper Forum, National Women's Theater Festival, and was selected as a representative of L.A. for the 1993 European Culture Capital Festival in Belgium.

Although lambasted for it by critics, she concurrently pursued work as a commercial choreographer and filmmaker, becoming a Sundance Dance/Film Lab and AFI Fellow. Amongst her most notable commercial successes, Sarah became the Music Performance Producer for the iconic *New Mickey Mouse Club*. Brought in to revamp what had become a floundering franchise, Sarah integrated her vocabulary of street urgency and avant-garde aesthetics to bring the music and dance numbers a more relevant edge, ultimately ushering in and developing the show's legendary, next generation including Britney Spears, Justin Timberlake, and Christina Aguil-

**Born Oak Park, IL
Lives and works in
Los Angeles, CA**

Select Education

Martha Graham School

Stanley Holden

Folkwang Hochschule

AFI/DWW

Sundance Dance/Film Lab

Select Performances

MASS MoCA, North Adams, MA

Jacob's Pillow, Becket, MA

Insitu Site-Specific Festival, New York, NY

Los Angeles International Airport, Los Angeles, CA

Bradbury Building, Los Angeles, CA

Cathedral Saint John the Devine, New York, NY

era. With this, Sarah moved her aesthetic into the exponentially far reaching scale of popular media, while simultaneously delving deeper into her work amongst the disenfranchised, emphatically empowering dance as a universal language. Perhaps it was at this crossroads that Sarah's singular artistic contribution and impact began to coalesce—the democratization of dance.

The prolific nature of Sarah's body of work continues in her passion for curating. She supports emerging, experimental, and under-represented dancers and filmmakers by providing them with a platform. Through her film festival, Dare to Dance in Public, as well as her writing for various publications, she continues to highlight international artists exploring the emerging genre of Dance Film, aka Screen Dance.

Sarah's kinetic storytelling continues to forge new spaces using visuals and movement to both reflect and disrupt stages, sites, and screens. She creates symphonies of bodies that alternately resist and surrender to gravity, achieving a level of poetry that leaves you breathless. Those who experience her work are encouraged to find truth in the gesture and magic in the mundane.

To live fully in Sarah Elgart's creations is to see the unseen and to cherish the extraordinary in the daily miracle of creativity.

Brian Brophy



Flyaway Home, 2010.
Performance at the Van Nuys Fly Away
Bus Terminal, Van Nuys, CA. Photo:
B. Schneider.

Still images from the new work titled *A Near Distance*
performed for video-broadcast on site at the Skirball Cultural Center,
Los Angeles, CA. Photo: Josh Caffrey.





Shape of Memory, 2018.
Performance in Beckett, MA. Photo: Door Eemaan.

Everywhere Nowhere, 2013.
Performance at Los Angeles International Airport,
Los Angeles, CA. Photo: Jorge Vismara.



Others, 2017.
Performance at Tongva Park,
Santa Monica, CA. Photo: Steve Pyne.





Lia
Halloran

In the mid-1920s Walter Benjamin posed a question that seems deeply relevant for any understanding of the process and effects of Lia Halloran's *The Sun Burns My Eyes Like Moons*. How might it be possible to make contact with, and navigate through, "the paroxysm of genuine cosmic experience"?^[1]

[1] Walter Benjamin, "One-Way Street" (1923-1926), trans. Edmund Jephcott in *Selected Writings*, Vol. 1, 1913-26, ed. Marcus Bullock and Michael W. Jennings (Cambridge: Harvard University Press, 2004), 487.

[2] Paul Cézanne, Letter to Emile Bernard, April 15, 1904 in John Rewald, ed.,

Cézanne's Letters (Oxford University Press, 1976), 301. This follows the famous injunction to "treat nature by means of the cylinder, the sphere, the cone."

[3] Yves Klein, Lecture at the Sorbonne, 1959; trans. in *Studio International Journal of Modern Art*, vol. 186, no. 961 (London, December 1973), 43. [4] - Walter Benjamin, "One-Way Street," 486.

[5] The fullest account of the Harvard computers is Dava Sobel's *The Glass Universe: How the Ladies of the Harvard Observatory Took the Measure of the Stars* (New York: Viking, 2016).

One approach, italicized by Halloran in the chromatically exacting space she elaborates between intense Cyanotype blues, the *ultra-noire* of Black 3.0 (an alternative to Vantablack, with more than 99% absorption of light) and the seething, laval ignition of solar "surfaces" themselves, is mapped-out by way of exalted and unearthly color adjudications. From the point of view of Halloran's work, the whitewashing of color in Suprematism and its putative opposite—seen for example in Cézanne's careful admonition in the name of spatial articulation "to introduce into our light vibrations . . . a sufficient amount of blueness to give the feel of air"[2]—are two sides of a still earthbound polarity beset, and possibly bankrupted, by abstraction, negation or grounded caution. Even the twentieth century's apotheosis of blue in the work and ideas of Yves Klein, which envisage the heavenly tint as a "pre-psychological expanse . . . beyond dimensions," tethers its experience to the denominations of the terrestrial governed by "sea and sky." [3]

Benjamin offers half an answer to the question he poses, looking back with a mix of nostalgia and redemptive futurity and to the era before the advent of the telescope, the lens and empirical observation (and their artificial redaction in the planetarium) during which technology betrayed the promise of ecstatic contact and trance—and perhaps the conundrum of cause itself. But for him, the loss attested here is manifest only in a ghostly negation as the besting by positivist science of the vatic imaginary erupted only in the hubristic depredations of mechanized warfare: "multitudes, gases, electrical forces . . . high-frequency currents . . . new constellations . . . aerial space and ocean depths thunder[ing] with propellers, and . . . everywhere sacrificial shafts" driven into mother Earth. [4]

Halloran broaches an altogether different response to the withering away of cosmological transport by quietly refusing the historical dichotomy that underwrites Benjamin's thinking. She reads between the lines of the scientific record in order to understand how star-gazers and solar aficionados, including Edwin Hubble—whose Mount Wilson observatory she can see from her north-east L.A. neighborhood—refused to uncouple the effects of marvel, even stupefaction, from their scientific records; how new understandings of solar energy were filtered through the work of a group of late 19th and early-20th century female scientists known as the "Harvard Computers"; [5] and how, in the matter of the flaring-up of the sun, aesthetic sensations cannot be short-circuited by scientific precept.

In fact, the predatory negation represented by war, and the collapse of color into white light, are re-orchestrated in Halloran's project in relation to one of the ultimate conditions of cosmological negativity: the eclipse. In August 2017 Halloran herself became an eclipse expeditionary, traveling to Oregon to witness a total solar eclipse and thereby joining the ranks of numerous women who for more than a cen-

**Born 1977,
Chicago, IL
Lives and works
in Los Angeles**

Education

MFA, Yale University, New Haven, CT, 2001

BA, University of California, Los Angeles, 1999

Selected Solo Exhibitions

2020
Double Horizon, ArtCenter, Pasadena, CA

Solar, Flatiron Institute, New York, NY

2019
The Same Sky Overarches Us All, University of Maryland Art Gallery, College Park, MD

Double Horizon, Luis De Jesus Los Angeles, Los Angeles, CA

Your Body is a Space That Sees, Schneider Museum, University of Southern Oregon, Ashland, OR

2018
Lia Halloran, LUX Institute, Encinitas, CA

Selected Bibliography

Battaglia, Andy. "How an Astrophysicist and a Painter Stared Down Black Holes," ARTNews, 2021.

Peschel, Joseph. "Lost in Space in 'Black Hole Survival Guide,'" *Boston Globe*, 2020.

Thorn, Kip & Halloran, Lia. "Poem: The Warped Side of Our University," *Scientific American*, 2020.

Cameron, Britta. "Lia Halloran: Double Horizon," *Flaunt Magazine*, 2020.

Black, Ezra Jean. "Lia Halloran: Double Horizon, Dark Passages, and Portraits of Consciousness," *Artillery Magazine*, 2019.

ture have trekked to vantage points all over the world in pursuit of a direct experience of the uncanny, ashen negative to which the almost complete loss of solar light gives rise—as they stand in what seems like the shadow of the sun. For 160 seconds, the duration of the 2017 eclipse, the earth appeared to furl its color, exchanging its diurnal being for something like a photographic process staged in reverse.

For Halloran it is the sensory impress of this experience that underwrites the layered processes informing the huge, seven-paneled piece in the present exhibition, joining as it does with the unfathomable combustion and unimaginably searing heat we read-off from remote telescopic images. The sheer sense of it all allows her to collapse the scaffolding of Benjamin's spectacular dissimulation (the planetarium) and the flea circus metaphoricity of his characterization of war. What results is a bid to overlay scientific observation, personal experience, and the dividends and losses of light in a gesture of aesthetic simultaneity that works through collage, cutting-out, the pitches of black, and renderings in line and color—the whole composed, and remaindered, in a mesmerizing blueprint of photographic emergence.

John C. Welchman

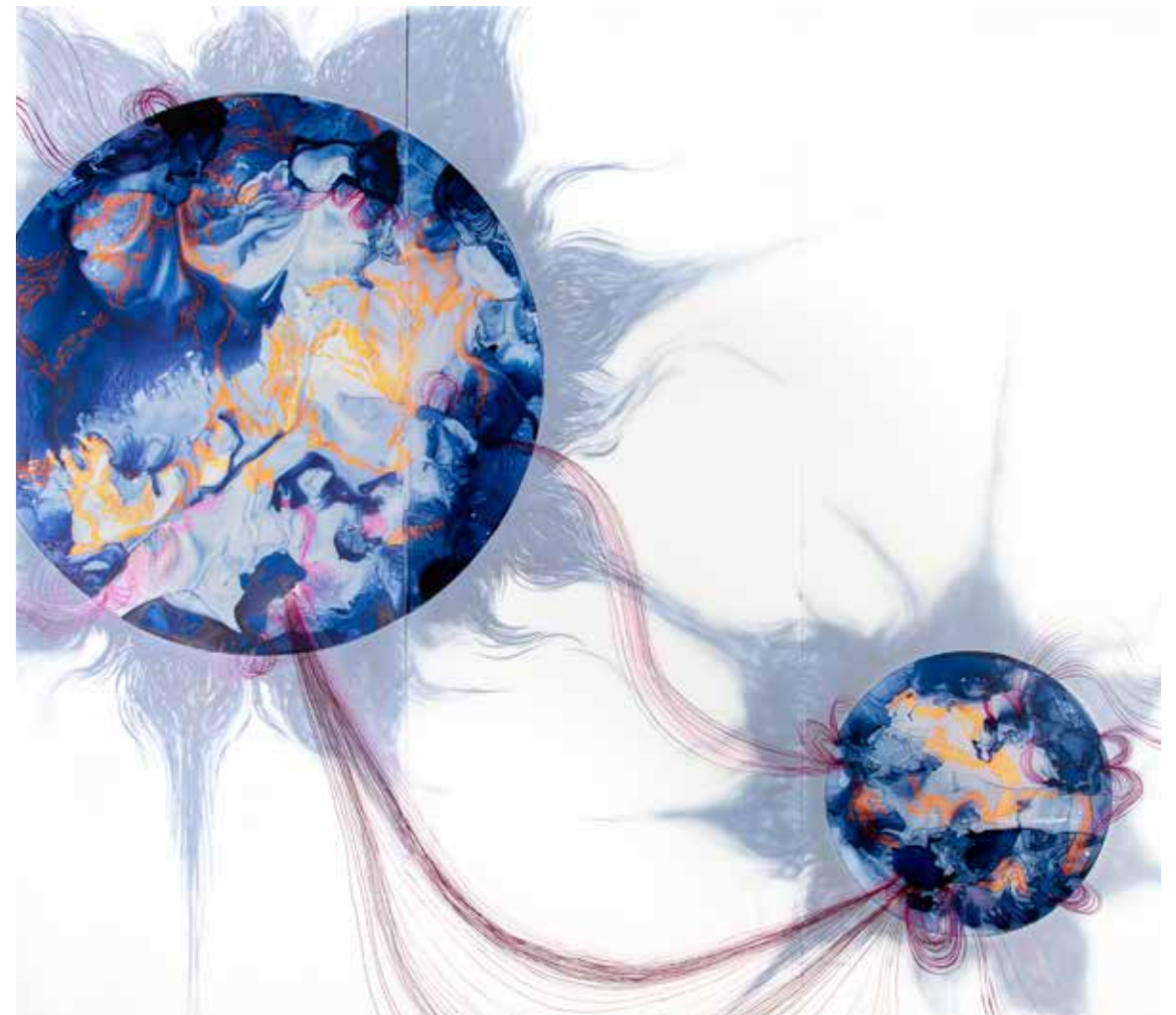
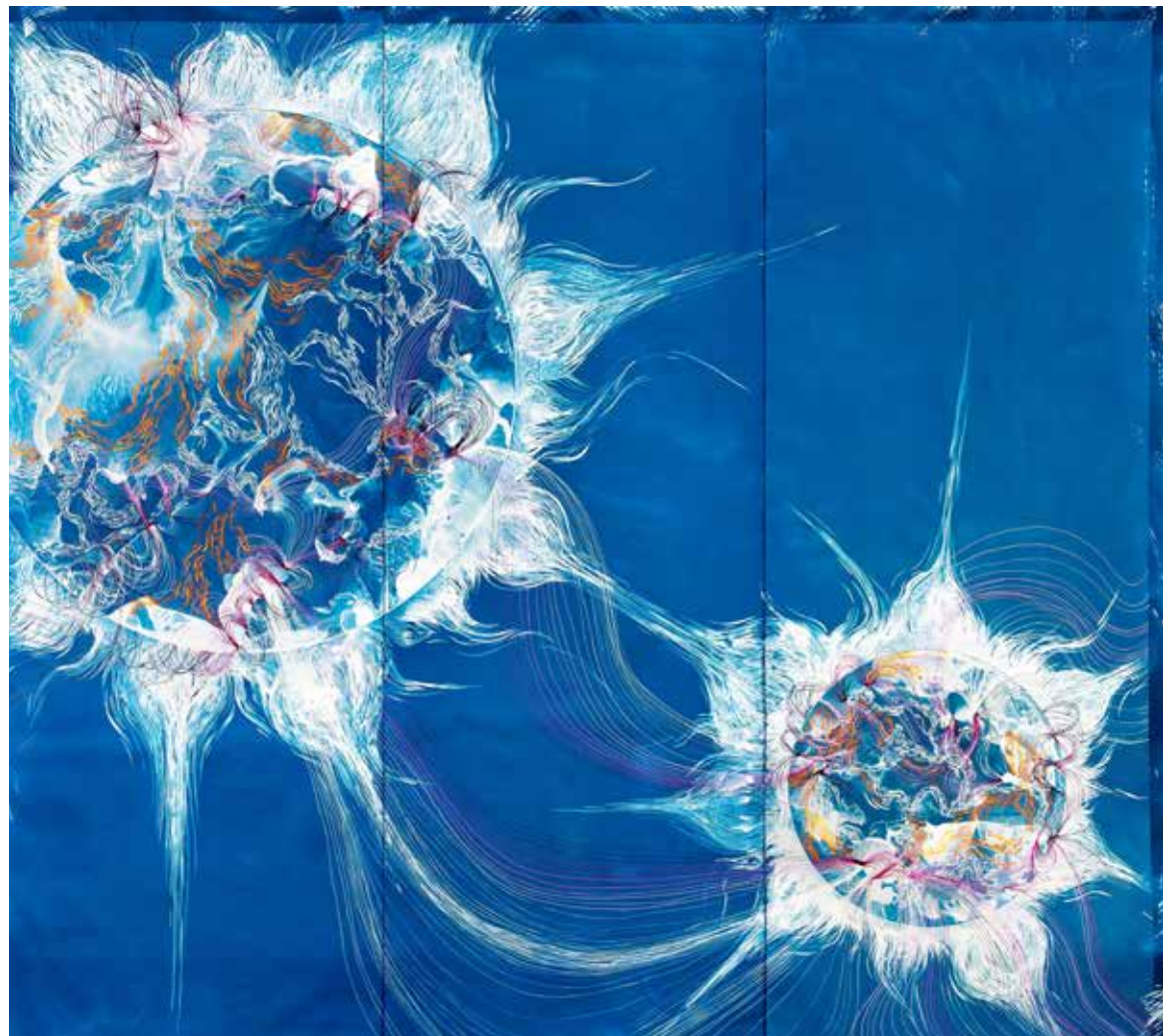

Solar (negative), 2019.
Ink on Duralar. 118 x 126 inches.
Photo: Adam Ottke.

Solar, 2019.
Cyanotype, acrylic and ink on paper
from painted negative. 120 x 131 inches.
Photo: Adam Ottke.



Paper Dolls, 2016–2019.
Cyanotype sun portraits of Nina Renata Aron, Diane Ackerman, Dava Sobel, Rebecca Oppenheimer, Jennifer Oulette, Janna Levin, Maria Popova, Anna Leahy, Lia Halloran. 45 x 126 inches each, 7 x 37 feet total. Photo: Adam Ottke.

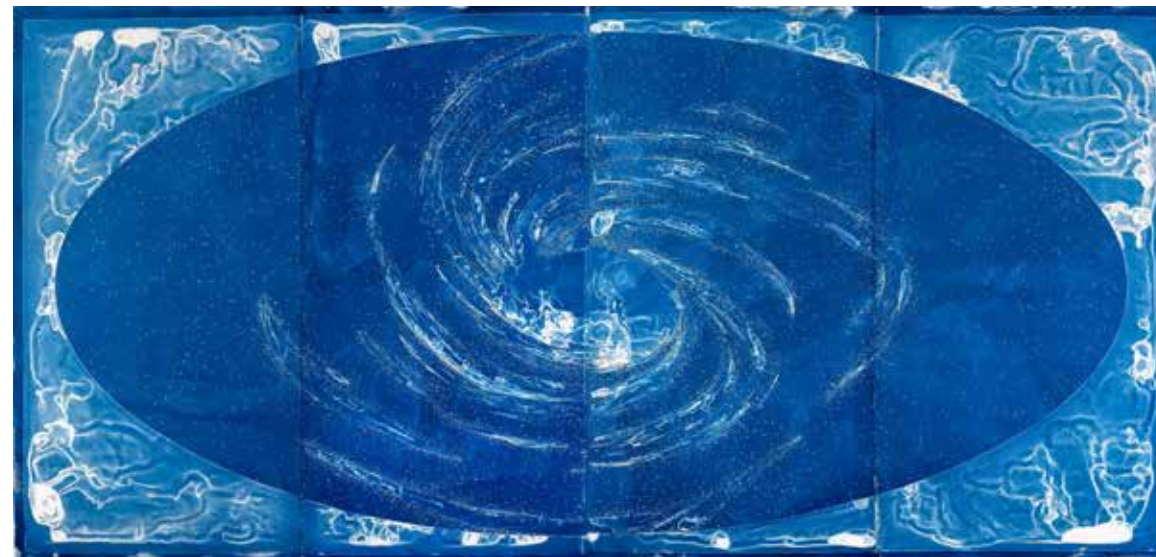

Triangulum, after Adelaide Ames, 2017.
Cyanotype on paper from printed negative. 84 x 176 inches.



The Great Comet, after Annie Jump Cannon, 2019. Cyanotype on paper from painted negative. 84 x 215 inches. Photo: Adam Ottke.

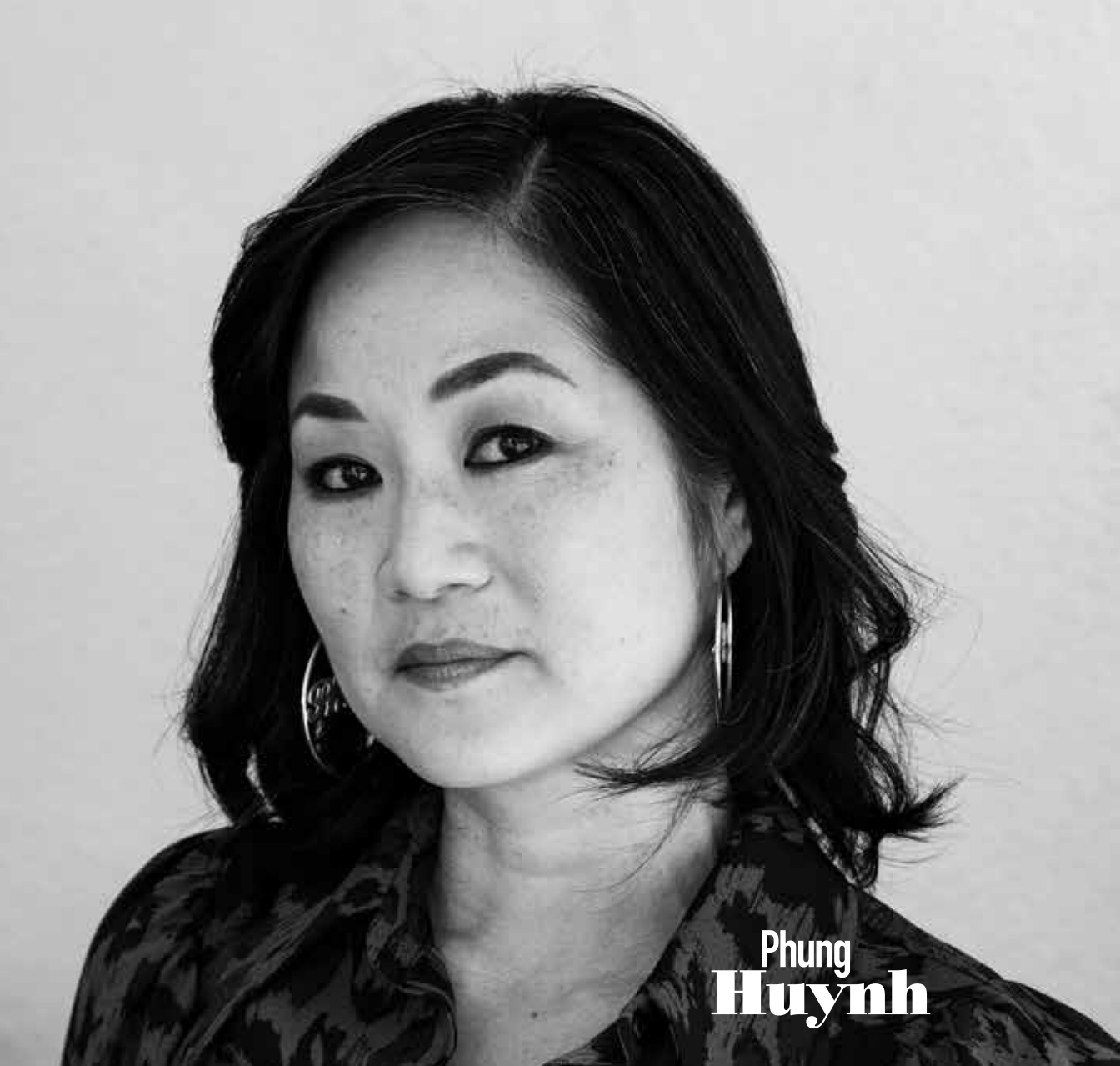

Phung
Huynh

On April 28, 1975, the final day of a failed 20-year war in Vietnam, entire families scrambled across Saigon to seek refuge in the U.S. Embassy. They clawed up fences and gates, throwing small bundles over barbed wire in hopes of boarding the helicopters that would eventually have them transported to the U.S. The exodus was triggered by a seemingly

inconspicuous signal over Armed Forces Radio: “The temperature in Saigon is 105 degrees and rising,” followed by the baritone voice of Bing Crosby singing “I’m Dreaming of a White Christmas.” American civilians, military members and select Vietnamese families had been instructed to keep the signal secret and “...not disclose to other personnel.” However, within 24 hours of the signal, nearly 7,000 people had escaped Saigon, nearly 6,000 of them Vietnamese. The chaos of this massive, desperate evacuation is evidence of a well-known fact: signals and codes are corruptible and fluid. They are slippery and mobile information that can circulate with alarming ease, especially in unintended hands. Culture, all codes and signals, is no different.

With sly dexterity, artist Phung Huynh handles the visual and linguistic codes embedded deeply and pervasively in Eastern and Western culture, subverting them to expose their violent underpinnings. Her paintings, drawings and sculptures directly address the coded languages trained on the body, particularly of Asian women and children, as they are shaped and portrayed in Western culture. From infancy, her own life was indelibly transformed by the Vietnam War as she and her family were also forced to seek refuge in the United States.

Huynh has centered much of her work on Asian bodies that both internalize and reject Western colonial values. Her paintings, namely her “Pretty Hurts” series, depict patriarchal, racist visual tropes and beauty standards that inflict violent procedures, such as foot-binding and plastic surgery, on women. But the women and children rendered in Huynh’s paintings and drawings, despite their burdens, appear buoyant, animated with an internal life revealed in a quiet but unmistakable wink, a reproachful gaze, or in some cases, an upturned middle finger. Inspired by W.E.B. DuBois’ concept of “double consciousness,” the women in Huynh’s paintings know their place as colonized subjects. They know the codes and how to navigate around them, with language, gestures, a grin and a gaze. Huynh reveals how the hollow codes of hegemony can be manipulated to imbue subjects with new, subversive power.

In her most recent work, Huynh continues to engage in the broad dialogues of empire, informed by Edward Said’s seminal writings on “orientalism,” but re-focuses her lens on her own personal and familial history as a refugee of the Vietnam War. Notably, Huynh shifts from painting and drawing to sculpture, mainly utilizing toys such as action figures, doll houses, and toy trucks. At eye level, her configurations of small green plastic soldiers seem like tableaux with the figures arranged in their classic, recognizable poses of battle—crawling belly-down or standing with a bayonet overhead. Like a monument or perhaps a Hollywood film, these poses evoke courage and loyalty. However, an overhead view, or the distance

**Born 1977,
Rach Gia, Vietnam
Lives and works in
Los Angeles, CA**

Education

MFA, New York University, New York, NY, 2001

BFA, ArtCenter College of Design, 1999

Undergraduate course work, University of Southern California, 1996

Selected Exhibitions

2021
Upon Closer Inspection, The University Gallery, San Diego State University, San Diego, CA (group)

2020
Gyre, Carolyn Campagna Kleefeld Contemporary Museum, California State University, Long Beach, CA (solo)

Resistance Aunties, Center for Creativity and the Arts, Fresno State University, Fresno, CA (solo)

We Are Here: Contemporary Art and Asian Voices in Los Angeles, USC Pacific Asia Museum, Pasadena, CA (group)

Selected Bibliography

Bui, Long. “Returns of War: South Vietnam and the Price of Refugee Memory,” New York University Press, 2018.

Bui, Thi. “The Best We Could Do,” Abrams Comicarts, 2018.

Hong, Cathy Park. “Minor Feelings: An Asian American Reckoning,” One World, 2020.

Huynh, Quan. “Sparrow in the Razor Wire,” Lioncrest Publishing, 2020.

of historical retrospection, reveals another message entirely. Huynh's soldiers spell out an anti-Asian slur: GOOK.

Huynh continues to delve into the narrative powers coded into toys in a set of snow globes sheentitles *White Christmas*. Each snow globe is inhabited not by a smiling snowman or a chimneyed log cabin, but by photographs from her early childhood. Huynh, her siblings and her mother, peer back from the snowy depths of memory. One person's white Christmas is another person's story of peril and permanent exile from home. Huynh plays with the double entendre of the *White Christmas*, while turning our attention to her family's difficult transition to the U.S., experiencing poverty, stigma and culture shock, as they were required to learn a new language and culture. However, despite the demands of assimilation, Huynh refuses to homogenize the experience of childhood so commonly rendered innocent and unscarred by personal and historical catastrophe. Her own life, family, and artwork are a testament to the survival of immigrants and refugees in the United States, whose stories are still waiting to be told and heard.

Carribbean Fragoza

White Christmas in Saigon (front view), 2021.
Mixed media sculpture. 24 x 20 x 10 inches.



Refugee Camp Snowglobe (front view), 2021.
Mixed media sculpture. 5 x 5 x 5 inches.

American G.I.'s Salute, 2021. Mixed media
sculpture. 3 x 32 x 10 inches.





Resistance Matriarch, 2019.
Oil paint on found painting. 36 x 30 inches.

American Enough, 2020.
Cotton fabric and embroidery thread. 5 x 10 inches.



Hoa Huynh (Dad), 2019–2020.
Graphite on pink donut box. 20 x 30.5 inches.



Farrah Karapetian

Although Farrah Karapetian abandoned her camera nearly two decades ago, her intermedial work continues to be discussed in terms of experimental photography or photography’s “expanded field.” After all, the artist uses light-sensitive paper and creates three-dimensional work that she refers to as “sculptural negatives,”

employing both strategies to create large-scale installations: Prints migrate from the wall to the floor or fold into a tent, and steel frames reorganize architectural space. More meaning might be gleaned, however, from the unusual medium description that has accompanied many of Karapetian’s images since 2009: “photogram *from performance*.”

Performance is key to Karapetian’s process-based work. The artist’s studio is a rehearsal space for protesters, soldiers, a drummer. Scuffling and striking in the dark, they are arrested by a bright light—their bodies absorb the glow, while the area around them develops into deep jewel tones of blue, purple, yellow, and orange. The ephemeral performance leaves behind an indexical image; but, like the ancient citizens of Pompeii, their bodily traces remain only as negative voids.

Critics frequently cite Karapetian’s “rejection” of documentary photography—specifically, the genre’s claim to truthful representation. For photograms such as *Riot Police* (2011), Karapetian employs performers to rework images drawn from mass media, bringing actions from public space into more intimate surroundings. Yet the artist remains committed to an element of authenticity, understood as the memory of lived experience in the body of the performer. Frequently, the performances grow out of firsthand experiences by original actors: an Egyptian revolutionary (*Flyer Photograph*, 2011), war veterans (*Muscle Memory*, 2013), her musician father (*Stagecraft*, 2014–15), clubgoers (*Collective Memory*, 2019).

As these are not strictly reenactments, Karapetian prefers the term *enactment*. The performers engage with “props” provided by the artist, such as cast resin sculptures of weapons or a glass drum kit, the transparency of which renders them skeletal in the final image; the objects are then exhibited alongside the photograms. Some works are still more layered, such as the installation *Collective Memory*: Using notes and floorplans drawn by friends and former patrons, Karapetian re-created the weekly trans night that took place at a recently defunct lesbian bar—a total mise-en-scène including a pool table, stripper pole, and barstools—and invited participation from gallery visitors; over the course of the exhibition, she created new photograms of these interactions, which in turn became part of the show.

Not every passing can be transformed into a joyous resurrection. The body of work that comprises *The Photograph Is Always Now* (2020), was completed shortly after the death of Karapetian’s father. It combines single portraits—of the artist and her father—with photograms of groups—hospital employees, grieving family members. The exhibition closed early as COVID-19 slammed the US in March 2020, and its themes and iconography are weirdly prescient: the ultimately solitary nature of death, even when visitors are allowed; the community of mourning that develops around loss; the toing and froing of front-line workers such as nurses and cleaners.

81

Born 1978 Lives and works in California

Education

MFA, University of California, Los Angeles, Los Angeles, CA, 2008

BA, Yale University, New Haven, CT, 2000

Selected Exhibitions

2020
The Photograph is Always Now, Diane Rosenstein Gallery, Los Angeles, CA (solo)

2020
Time Share for Radical Broadcast, Performa, New York, NY (group)

2019

Collective Memory, Von Lintel Gallery, Los Angeles, CA (solo)

2018

The Fabric of Felicity, Garage Museum of Contemporary Art, Moscow, Russia (group)

ЭТЮДЫ ПО БЕЗОПАСНОСТИ / Security Studies, New Holland Island Pavilion, St. Petersburg, Russia (solo)

2017

Synthesize, MOCA Jacksonville, FL (group)

Light Play: Experiments in Photography, 1970 to the Present, Los Angeles County Museum of Art, Los Angeles, CA (group)

Selected Bibliography

Marien, Mary Warner. “Photography: A Cultural History.” Lawrence King Publishing, 2020.

Osberg, Annabele. “Top Ten Exhibitions from 2019 in Los Angeles (Collective Memory),” *Artillery Magazine*, 2020.

Osberg, Annabele. “Critic’s Pick. Review of Collective Memory,” *Artforum*, 2019.

Mizota, Sharon. “Review of Collective Memory,” *LA Times*, 2019.

www.farahkarapetian.com

The last year has separated Karapetian from collaborators, necessarily altering her practice. For her latest project, she looks to the past, investigating historical relationships. Her focus is on the women who were central to the artistic, literary, and political movements of the interwar period—Négritude, Surrealism, pan-Africanism, anti-fascism: among them, Lola Álvarez Bravo, Claude Cahun, Suzanne Césaire, Frida Kahlo, Ida Kar, Jacqueline Lamba, Dora Maar, Lee Miller, and the Nardal sisters. Relying solely on primary sources for her research, Karapetian will reimagine the women's voices in a script and reproduce their material attributes and environments—a cane, early modern furniture—as sculpture and installation. Despite their contributions, many of these artists and writers have long been overshadowed by husbands and lovers. As she maps out this proto-feminist network, Karapetian hopes to bring these women further into the light.

Nikki Columbus

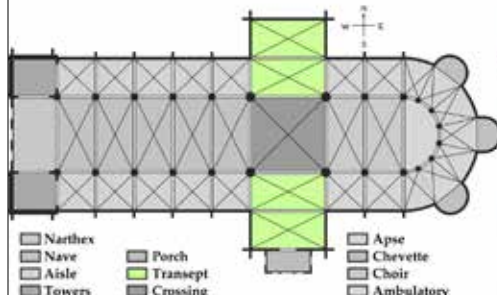
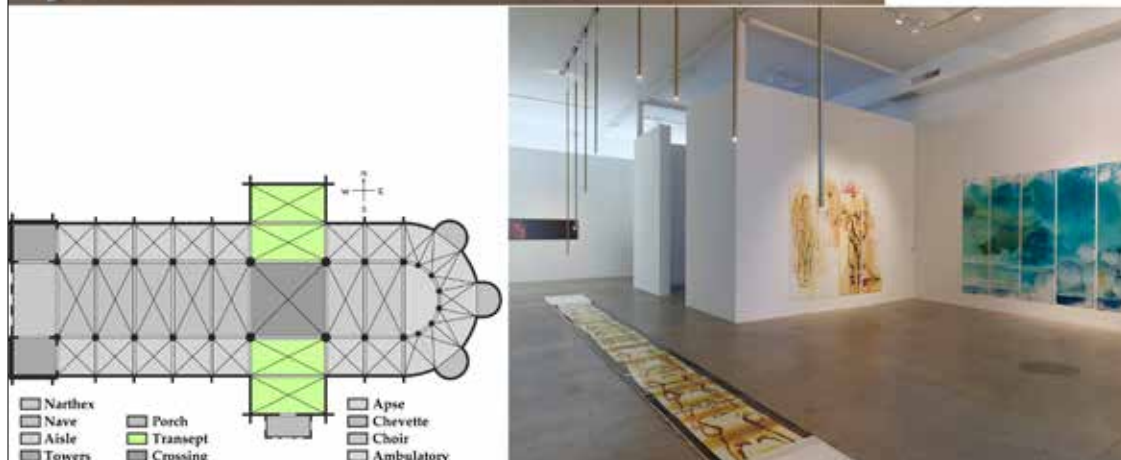
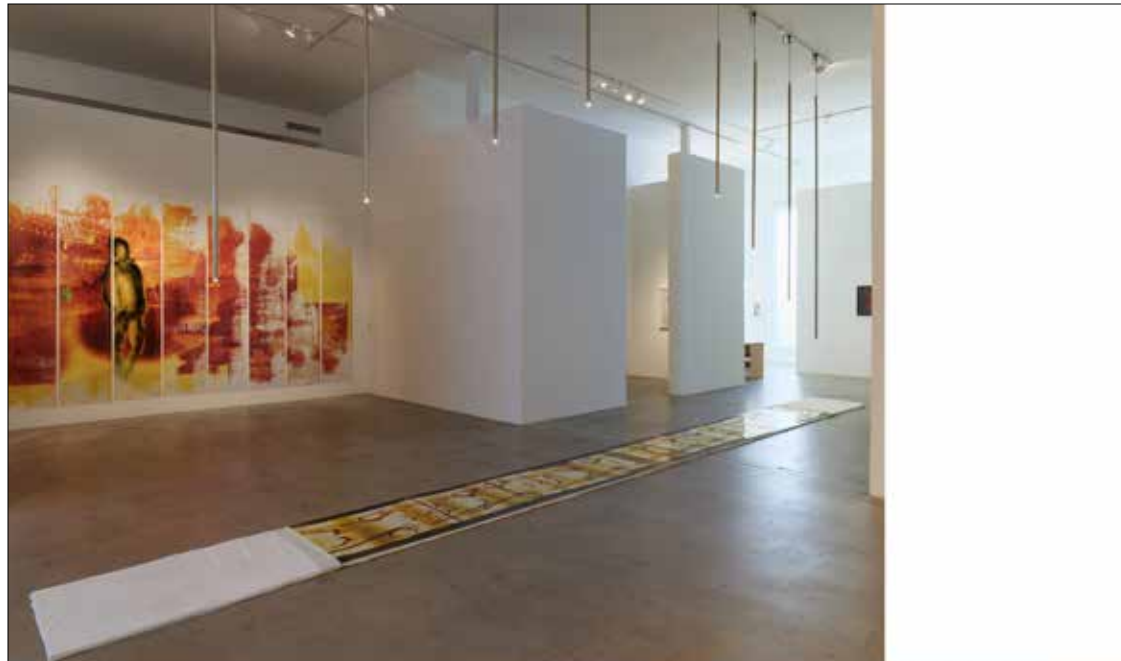

The Photograph is Always Now, 2020.
Installation view, photographs from digital drawings and performance, and details. Photo: Marten Elder.

Collective Memory, 2019.
Installation views of photograms from performance and source material at Von Lintel Gallery, Los Angeles, CA. Photo: Marten Elder.

Accessory to Protest, 2018.
Installation view, photographs from constructed negatives and performance, and source material at Garage Museum of Contemporary Art, Moscow, Russia.

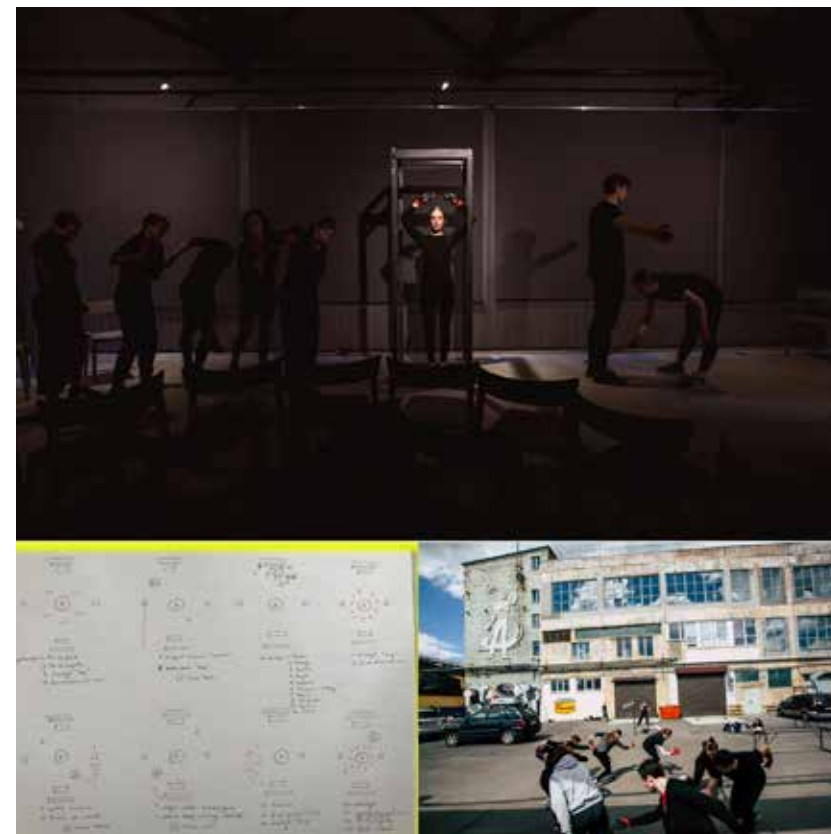

The Gesture of Safe and Sanitary: ICE (pillow), 2019. Single channel video with sound, using constructed negative. 1 minute 16 seconds.

Security Studies, 2018.
Installation view of performance and development details at New Holland Island, St. Petersburg, Russia. Photo: Vadim Frolov.



Ruben
Ochoa

In Southern California, to look into someone's vehicle is to gaze deep into their history. Automobiles are artifacts that absorb the stains, crumbs and choques of our everyday lives. What you see here, with its door wide open, is an open heart; a legendary vehicle that has served numerous publics and purposes as a family van, a tortilla delivery

van, a mobile Mexican tiendita, an art gallery; it was even stolen by coyotes, and now, it is a monument to how immigrants make this country.

In 1977, María Guadalupe "Lupe" Gonzalez Ochoa began selling tortillas by foot in Oceanside, California. Her venture quickly expanded into a family-run fleet of delivery vans. This 1985 Chevy Cargo-van was part of the mobile infrastructure which made Mexican food stuffs easily purchasable and part of everyday life in Southern California. Here, there is not just history, there is knowledge.

A fine example of the Mexican spatial thinking that brought you el paletero, el elotero, el frutero, and la florista, this roving tiendita was born from a particular way of seeing and being in the world. Always with the pointy end of capitalism at their backs, working class gente have expertly walked the line between legal and illegal, formal and informal, business and family to make life livable. In a country where this type of thinking, and the bodies that power it, can become a putative threat to every corner, survival is won by dando la vuelta a esta vida Americana. Maybe you might have caught a glimpse of the little kid sitting on a milk crate between pillars of teetering tortillas in the back of this van.

Maybe you might have come across the vans on a sidewalk selling conchas and Mexican candies, or maybe you heard their melodic horns. Maybe you never did, but, dear reader, it is easy to envision because immigrants like Lupe made Mexican sounds, tastes and spaces an integral part of contemporary American life.

Lupe's son, Ruben, a young artist trying to make a way in the exclusionary white art establishment, returned to this familiar rasquache sensibility and turned the mobile tiendita into an art gallery. As Ruben had been taught in those tortillero years: if they tell you not to park there, well, *mijo*, you gotta make your own ruta. The trick was seeing the world as malleable so that the steeliest materials and most immovable structures became pliable and useful, like warm tortillas in your hands.

From 2001–2005, this van, now called CLASS: C, held exhibitions all over Southern California. Mimicking the tactics of the original tiendita, it posted up in parking lots, gas stations, and city blocks. An artwork, for sure, it was more importantly a form of guerilla space-making that tested what other work art could do in the world beyond the gallery.

With doce paquetes de tres docenas of bronze tortillas stacked like coinage, the van has again shifted shape. Gone are the days when Ruben's father made deals with locals over unpaid tabs and bartered pounds of tortillas for new puppies (that old-school style of doing business under the honor system). Gone, too, those hot summers selling to fieldworkers. The necessity of knowing how to make do with little, however, remains.

**Born 1974,
Oceanside, CA
Lives and works
in Los Angeles, CA**

Education

MFA, University of California, Irvine, CA, 2003

BFA, Otis College of Art and Design, Los Angeles, CA, 1997

Selected Exhibitions & Public Projects

2021
iVendedores, Presente!, LACMA x Snapchat: Monumental Perspectives, Los Angeles, CA

2020
Vote / Votar / Τούπαίο, Los Angeles, CA

2017

Sampled y Surveyed, Art + Practice, Los Angeles, CA (solo)

Down These Mean Streets, Smithsonian American Art Museum, Washington DC (group)

2013
X-Change, Nasher Sculpture Center, Dallas, TX (group)

2010
Building on the Fringes of Tomorrow, Museum of Contemporary Art, San Diego, CA (solo)

2008
WHITNEY BIENNIAL, Whitney Museum of American Art, New York, NY (group)

Selected Awards

2013
California Community Foundation: Getty Fellow, Mid-Career Artist

2008
John Simon Guggenheim Memorial Foundation Fellowship

2005
Creative Capital Foundation: Visual Arts Grant

Selected Bibliography

Wagner, Sandy. "Sweat Equity: A Conversation with Ruben Ochoa." *Sculpture Magazine*, 2016.

Miranda, Carolina A. "Ruben Ochoa's Concrete Poetry," *ARTnews*, 2014.

Now, this van is a monument. Firstly, to Doña Lupe and las mamás, tías y abuelas who have traditionally been the tortilla-makers and movers, whose labor is unjustly devalued in our culture because of their gender. Secondly, to those countless Latino families who have always found a way within an economic order that devalues almost anything they do. Thirdly, to the tortilla itself, one of the greatest inventions of the Americas.

These bronze tortillas, Ruben told me, might one day be converted into compensation for his mom's hard work. Those who know the struggle of choosing an artistic path as a Latinx can surely empathize with this obligation, as well as the obstacles we encounter in professions not defined by us. It is all part of the package. Before you is an archive of knowledge stacked with handmade histories, pressed by the forces of life to lose all trace of human touch, but are nonetheless, handmade sculptures from the heart of a culture.

J.V. Decemvirale



Las Tortillas, 2021 featuring Arturo "The Van Guard" cutout and CLASS: C mobile gallery. Courtesy of the Artist and CLASS: C. Photo: Pete Galindo.

Las Tortillas, 2021.
Bronze. 12.5 x 17.25 x 24.25 inches (installation), 2.5 x 5.75 inches (each).
Courtesy of the Artist and CLASS: C.
Photo: Pete Galindo.



Las Tortillas, 2021.
Bronze. 12.5 x 17.25 x 24.25 inches
(installation), 2.5 x 5.75 inches (each).
Courtesy of the Artist and CLASS: C.
Photo: Pete Galindo.





Umar
Rashid

If your dreams walked with you across town they would die from overwork. Umar Rashid works in synchronizations, reimagining colonial Los Angeles in order to shift the power dynamics of visual culture. He studies, substitutes and recontextualizes historical moments into a language that is at once challenging and sublime.

Much has been written about Rashid's work and his numerous solo exhibitions around the world. Each one is like a page in a codex—a branch of his epic narrative that, with multiple modalities, questions the weight and truth of history and our visual literacy of the past and present. Coalescing figures borrowed from Egypt, Vodun and other world religions, Afrofuturist symbols, as well as military and colonial imagery, Rashid's lexicon is more than the sum of its parts.

Rashid's COLA project, *Per Capita*, rigorously extends his already complex, rich practice into three dimensions. Transcending the confines of the white cube, *Per Capita* reimagines Babylon's Ishtar Gate, transformed into a portal connecting the misery of colonial Los Angeles to a different realm, but one that goes nowhere. Using sound, light, two- and three-dimensional materials, this new gate incorporates the symbols of power that created Los Angeles—a confluence of European imperialism, American capitalist neocolonial systems, Indigenous cultural production of the Tongva Indians, and Black and Brown communities under the governorship of the Black Mexican, Pio Pico.

Per Capita contests hegemony, progress and time. A cosmic sculptural journey into colonial L.A. is a processional through the city's ongoing institutionalization of hubris and inequality, and collective subaltern creative resistance. Rashid notes, "My conceptual interest in the gate as a monument is the particular language of migration and inclusion in nation building, religion, and culture founded on existing temporalities."

Rashid's lens for historical and contemporary review is always broad yet specific. Ishtar is a goddess of fertility, love, sex, and war, and this complexity—a seemingly contradictory repertoire—is used to full effect in *Per Capita*. Invoking a more equitable history, the installation including the twelve foot gateway and accompanying sculptures and paintings, connects an iconic emblem of the past to the undocumented past, present and subsequent futures of Los Angeles. The artifact's original bulls and dragons are replaced with Rashid's vocabulary, specifically cougars, lions symbolizing California and the totem of Ishtar, and jaguars, signifying the indigenous peoples who fought for colonial Spain. Sculpted busts of various gods represent actors in the historical narrative and paintings depict battle scenes for the soul of L.A.

The Ishtar Gate becomes Rashid's parable of the Black diaspora. Made by Babylonian King Nebuchadnezzar circa 575 BCE, the gateway and its processional were adorned, in the king's words, with "luxurious splendor so that people might gaze on them in wonder," yet after the empire fell, the components of the gate were scattered and subsumed into the collections of large western colonial and neoliberal states responsible for the cultural and financial theft and oppression of much of

**Born 1976,
Chicago, IL
Lives and works in
Los Angeles, CA**

Education

BA, Southern Illinois University at Carbondale, Carbondale, IL, 2000

Selected Exhibitions

2020
Made In LA: A Version, Hammer Museum and The Huntington Art Museum, Los Angeles, CA (group)

In the Court of the Crimson Queen (Or, white Lady on a Horse), Tiwani Contemporary, London, UK (solo)

Money over everything. Power before anything. It blows my mind, but it's like that. (The life of Ambroos Van Peere, a tragicom-

edyDutch Guiana, 1793), Cokkie Snoei, Rotterdam, Netherlands (solo)

2019
The world you know is a fiction. (You know we had to do a remix right?), Vincent Price Art Museum, Los Angeles, CA (solo)

Selected Bibliography

Williams, Gilda. Review, *Artforum*, 2020.

Caldwell, Ellen C. "Umar Rashid's What is the Color, When Black is Burned? Riot Material, 2018.

Pierrot, Gregory, "To be the other of an other: An encounter with Frohawk Two Feathers", *ASAP/ Journal*, 2017.

www.frohawktwofeathers.com

the world. How a splendid object, once prided as one of the seven wonders of the world, could be fractured, dispersed and claimed by tyranny is demonstrative of the machinations of power that Rashid's work so eloquently and often brutally examines.

Inspired by the song "Something in the Way of Things" by The Roots featuring Amiri Baraka, Rashid is concerned with visualizing and putting sound to what refuses to be called by name. Something liminal, at once ugly and beautiful, death and rebirth—like Ishtar, a convergence of contradictions, a cyclic representation of the universal totality of the divine and the discarded, subjugated stories of the other upon which western history is written. Rashid may use his existing codex to inform *Per Capita*, but the project completes a separate circle of creation to judge the city and ourselves in this moment that comes from the past and goes nowhere.

Due to limitations imposed by COVID-19, Rashid is rescaling the installation as a statement about both the changing dynamics of the COLA fellowship and the city's uneven and inequitable response to the pandemic and other ongoing crises. As always, he unfalteringly answers these critical inequities with a redistribution and consideration of what winning and writing history really means, and how much that authorship matters.

jill moniz

Per Capita, 2021.
Acrylic and mica flake on canvas.
48 x 48 inches.



Lo Life. (Good Sport) The 1st RL Equestrian Games, sponsored by Sir Ralph Lauren at Bronck's Farm after the defeat of The Kingdom of Holland and Zeeland in Novum Eboracum (New York) 1794., 2021. Acrylic and Micah flake on canvas. 48 x 48 inches.

Tennyson. (Crost The Line). Or, Ashe defeats the Borg, single handedly in 6 straight sets in the Ifa System., 2021. Acrylic and mica flake on canvas. 48 x 48 inches.





La Caballeria Baile. Those dancing days. (Killa/Priest), 2015.
Acrylic and ink on paper stained with coffee and tea.
45 x 69.5 inches.

Let's ride! (for victory), 2017.
Ink on paper stained with coffee and tea. 45 x 69.5 inches.



A Fleetwood Fitzcarraldo, 2019.
Acrylic and mica flake on canvas.
72 x 72 inches.

COLA History

C.O.L.A. 2020 Individual Artist Fellowships

Tanya Aguiñiga
Amir H. Fallah
YoungEun Kim
Elana Mann
Hillary Mushkin
Alison O'Daniel
Roxanne Steinberg Oguri
Vincent Ramos
Steven Reigns
Shizu Saldamando
Holly J. Tempo
Mia Doi Todd
Jeffrey Vallance
Lisa Diane Wedgeworth

Panelists

Sandra de la Loza
Daniela Lieja
Edgar Miramontes
Kelsey Nolan
Doris Sung
Kristina Wong
Steven Wong

Acknowledgements

DCA would especially like to thank the following DCA employees for their dedicated work toward making this year's initiative engaging, educational, and entertaining: Joe Smoke, Ben Espinosa, and Brenda Slaughter Reynolds from the Grants Administration Division; Will Caperton y Montoya, Gabriel Cifarelli, and William Ramirez from DCA's Marketing, Development, Design, and Digital Research Division; Isabelle Lutterodt, Jamie Costa, John Weston, Roberto Pineda-Silva, Stephanie Sherwood, Mary Oliver, Marta Feinstein, Elli Butler, Prima Jalichandra-Sakuntabhai, Marissa González-Kuchek, Agata Gravante, Anais Franco, and Alberto Keossian from the Los Angeles Municipal Art Gallery; and Ben Johnson and Christopher Reidesel from the Performing Arts Program.

DCA also sincerely thanks: Garland Kirkpatrick for his design of the catalog; Josh Caffrey for his portraits of the artists; and Erik Benjamins for his copy-editing.